

# CELEBRATING

## CHRISTMAS AND OTHER HOLIDAYS AROUND THE WORLD



CREATED BY PRIMARY JUNCTION

WWW.PRIMARYJUNCTION.NET



# beginning the unit

Begin by showing your students a globe and discussing towns, states, countries, continents, etc. Talk about how we are free to visit other states, but when we want to visit another country, it requires some paperwork. Briefly explain that in order to visit other countries we must have a passport. Ask students why they think this is.

Then, introduce the Christmas Around the World Unit by telling students they will be “visiting” several countries to learn about their cultures and holiday traditions, and in order to do this, they will have to apply for a passport and be granted one before they are allowed to travel. Depending on your time constraints, you may want to introduce the unit and have students fill out their passport application on day one and then on day two meet with students to approve their applications and grant passports.

When filling out applications, you will need to guide students through the passport. When I approve applications, I stamp the top of the application with a [stamp](#) that says ‘Approved’ or either write it in red ink.



# UNITED STATES PASSPORT APPLICATION

First Name \_\_\_\_\_ Middle Name \_\_\_\_\_ Last Name \_\_\_\_\_

Date of Birth \_\_\_\_\_ Place of Birth \_\_\_\_\_ Gender \_\_\_\_\_

Occupation \_\_\_\_\_ Hair Color \_\_\_\_\_ Eye Color \_\_\_\_\_

Mailing Address \_\_\_\_\_ City \_\_\_\_\_

State \_\_\_\_\_ Zip Code \_\_\_\_\_

I plan to leave the United States of America on:

I plan to visit the following countries while abroad:

1. \_\_\_\_\_
2. \_\_\_\_\_
3. \_\_\_\_\_
4. \_\_\_\_\_
5. \_\_\_\_\_
6. \_\_\_\_\_

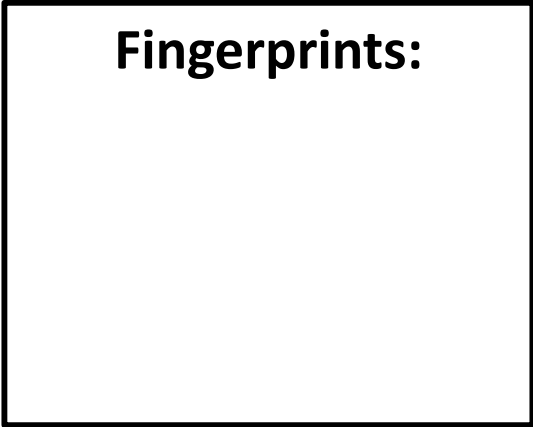

I plan to return to the United States of America on:

*While traveling abroad, I promise to be a citizen of the world and learn about and respect the cultures of others.*

Applicant's Signature \_\_\_\_\_

Date Signed \_\_\_\_\_

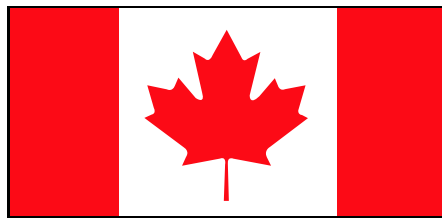

# CANADA PASSPORT APPLICATION

First Name \_\_\_\_\_ Middle Name \_\_\_\_\_ Last Name \_\_\_\_\_

Date of Birth \_\_\_\_\_ Place of Birth \_\_\_\_\_ Gender \_\_\_\_\_

Occupation \_\_\_\_\_ Hair Color \_\_\_\_\_ Eye Color \_\_\_\_\_

Mailing Address \_\_\_\_\_ City \_\_\_\_\_

Province \_\_\_\_\_ Postal Code \_\_\_\_\_

I plan to leave Canada on:

\_\_\_\_\_

I plan to visit the following countries while abroad:

1. \_\_\_\_\_
2. \_\_\_\_\_
3. \_\_\_\_\_
4. \_\_\_\_\_
5. \_\_\_\_\_
6. \_\_\_\_\_



I plan to return to Canada on:

\_\_\_\_\_

*While traveling abroad, I promise to be a citizen of the world and learn about and respect the cultures of others.*

Applicant's Signature \_\_\_\_\_

Date Signed \_\_\_\_\_

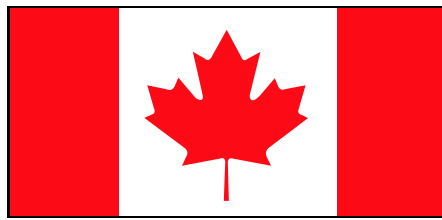

# CANADA PASSPORT APPLICATION

First Name \_\_\_\_\_ Middle Name \_\_\_\_\_ Last Name \_\_\_\_\_

Date of Birth \_\_\_\_\_ Place of Birth \_\_\_\_\_ Gender \_\_\_\_\_

Occupation \_\_\_\_\_ Hair Colour \_\_\_\_\_ Eye Colour \_\_\_\_\_

Mailing Address \_\_\_\_\_ City \_\_\_\_\_

Province \_\_\_\_\_ Postal Code \_\_\_\_\_

I plan to leave Canada on:

\_\_\_\_\_

I plan to visit the following countries while abroad:

1. \_\_\_\_\_
2. \_\_\_\_\_
3. \_\_\_\_\_
4. \_\_\_\_\_
5. \_\_\_\_\_
6. \_\_\_\_\_

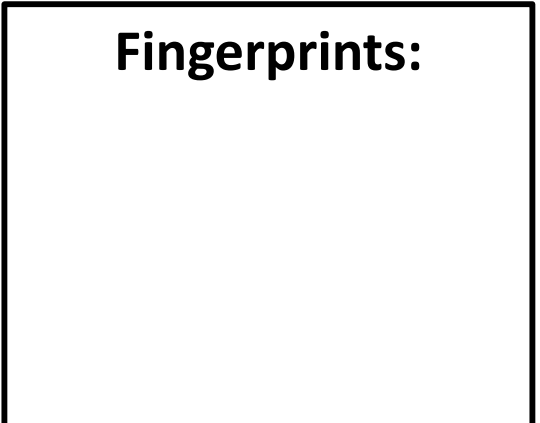

I plan to return to Canada on:

\_\_\_\_\_

*While traveling abroad, I promise to be a citizen of the world and learn about and respect the cultures of others.*

Applicant's Signature \_\_\_\_\_

Date Signed \_\_\_\_\_

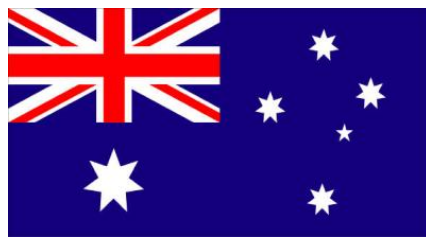

# AUSTRALIA PASSPORT APPLICATION

First Name \_\_\_\_\_ Middle Name \_\_\_\_\_ Last Name \_\_\_\_\_

Date of Birth \_\_\_\_\_ Place of Birth \_\_\_\_\_ Gender \_\_\_\_\_

Occupation \_\_\_\_\_ Hair Colour \_\_\_\_\_ Eye Colour \_\_\_\_\_

Street Address \_\_\_\_\_ Town/Suburb \_\_\_\_\_

State \_\_\_\_\_ Postal Code \_\_\_\_\_

I plan to leave Australia on:

\_\_\_\_\_

I plan to visit the following countries while abroad:

1. \_\_\_\_\_
2. \_\_\_\_\_
3. \_\_\_\_\_
4. \_\_\_\_\_
5. \_\_\_\_\_
6. \_\_\_\_\_

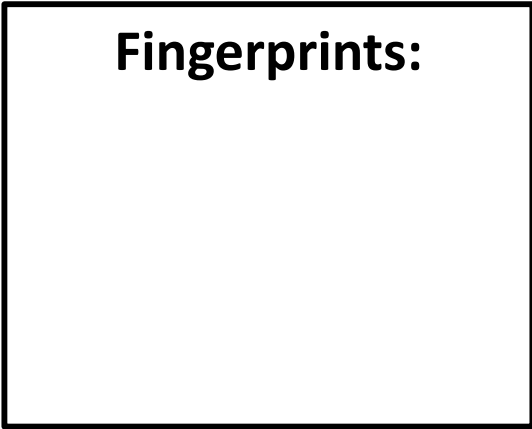

**Fingerprints:**

I plan to return to Australia on:

\_\_\_\_\_

*While traveling abroad, I promise to be a citizen of the world and learn about and respect the cultures of others.*

**Applicant's Signature** \_\_\_\_\_

**Date Signed** \_\_\_\_\_

# PASSPORT APPLICATION

First Name \_\_\_\_\_ Middle Name \_\_\_\_\_ Last Name \_\_\_\_\_

Date of Birth \_\_\_\_\_ Place of Birth \_\_\_\_\_ Gender \_\_\_\_\_

Occupation \_\_\_\_\_ Hair Colour \_\_\_\_\_ Eye Colour \_\_\_\_\_

Mailing Address \_\_\_\_\_  
\_\_\_\_\_  
\_\_\_\_\_

I plan to leave the country on:

\_\_\_\_\_

I plan to visit the following countries while abroad:

1. \_\_\_\_\_
2. \_\_\_\_\_
3. \_\_\_\_\_
4. \_\_\_\_\_
5. \_\_\_\_\_
6. \_\_\_\_\_

**Fingerprints:**

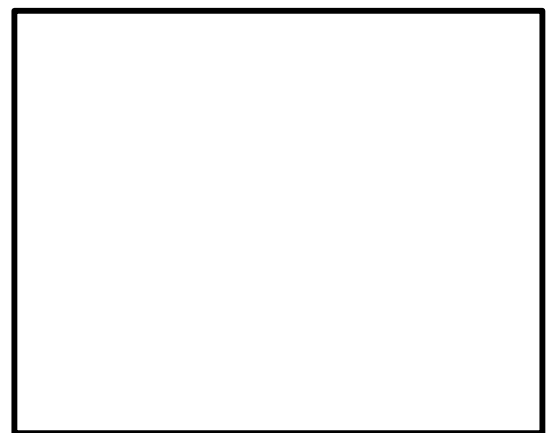

I plan to return to the country on:

\_\_\_\_\_

*While traveling abroad, I promise to be a citizen of the world and learn about and respect the cultures of others.*

Applicant's Signature \_\_\_\_\_

Date Signed \_\_\_\_\_

# PASSPORT APPLICATION

First Name \_\_\_\_\_ Middle Name \_\_\_\_\_ Last Name \_\_\_\_\_

Date of Birth \_\_\_\_\_ Place of Birth \_\_\_\_\_ Gender \_\_\_\_\_

Occupation \_\_\_\_\_ Hair Color \_\_\_\_\_ Eye Color \_\_\_\_\_

Mailing Address \_\_\_\_\_  
\_\_\_\_\_  
\_\_\_\_\_

I plan to leave the country on:

\_\_\_\_\_

I plan to visit the following countries while abroad:

1. \_\_\_\_\_
2. \_\_\_\_\_
3. \_\_\_\_\_
4. \_\_\_\_\_
5. \_\_\_\_\_
6. \_\_\_\_\_

**Fingerprints:**



I plan to return to the country on:

\_\_\_\_\_

*While traveling abroad, I promise to be a citizen of the world and learn about and respect the cultures of others.*

Applicant's Signature \_\_\_\_\_

Date Signed \_\_\_\_\_



# using the passports

Once students have been approved for their passport, hand them a copy of their passport. First, have students fill out the information portion of the passport and place their photo in the section as well. As for students' passport photos, I always get a few extra photo stickers of students from portraits at the beginning of the school year, and they are excellent for this project!

Students can then color the front of their passport. When finished, they should place their passport (and application, if you choose) in their suitcase. Remind them to take good care of their passport and not lose it because they must have it to enter countries during their trip!

When students are ready to visit a country, have them get their passports out and ready. When entering, the "border control" should welcome them to the country and stamp their passport. You can use the included labels (designed for Avery Multi-Use Labels 5410 – 1" round) or purchase a set of Christmas stamps to use (Oriental Trading has a great set [here!](#))

primary junction

*Holidays Around The World*



PASSPORT

*This passport states  
the carrier is a  
citizen of the world  
who learns about  
and respects the  
cultures of others.*



**Name** \_\_\_\_\_

**Country:** \_\_\_\_\_

**Birth Date** \_\_\_\_\_

**Hair Color** \_\_\_\_\_

**Eye Color** \_\_\_\_\_

**Issue Date** \_\_\_\_\_

**SWEDEN**

**MEXICO**

**ISRAEL**

**ITALY**

**CHINA**

**ENGLAND**

**ETHIOPIA**

**FRANCE**

**GERMANY**

**HOLLAND**

*Holidays Around The World*



# PASSPORT

*This passport states  
the carrier is a  
citizen of the world  
who learns about  
and respects the  
cultures of others.*

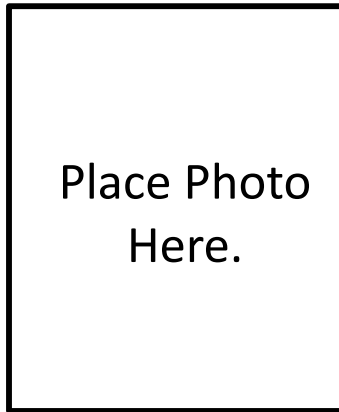

**Name** \_\_\_\_\_

**Country:** \_\_\_\_\_

**Birth Date** \_\_\_\_\_

**Hair Color** \_\_\_\_\_

**Eye Color** \_\_\_\_\_

**Issue Date** \_\_\_\_\_

**CHINA**

**ENGLAND**

**GERMANY**

**ITALY**

**MEXICO**

**SWEDEN**

*Holidays Around The World*



PASSPORT

*This passport states  
the carrier is a  
citizen of the world  
who learns about  
and respects the  
cultures of others.*

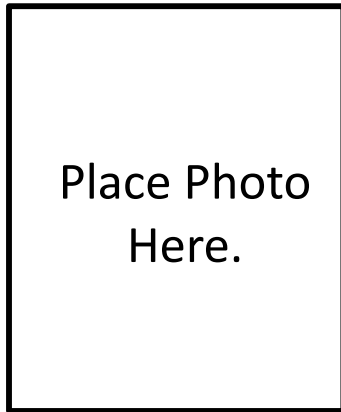

Name \_\_\_\_\_

Country: \_\_\_\_\_

Birth Date \_\_\_\_\_

Hair Color \_\_\_\_\_

Eye Color \_\_\_\_\_

Signature \_\_\_\_\_

**CHINA**

**GERMANY**

**ENGLAND**

**ETHIOPIA**

**MEXICO**

**SWEDEN**

*Holidays Around The World*



PASSPORT

*This passport states  
the carrier is a  
citizen of the world  
who learns about  
and respects the  
cultures of others.*

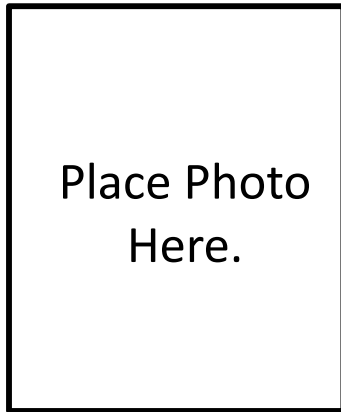

**Name** \_\_\_\_\_

**Country:** \_\_\_\_\_

**Birth Date** \_\_\_\_\_

**Hair Color** \_\_\_\_\_

**Eye Color** \_\_\_\_\_

**Issue Date** \_\_\_\_\_

**ENGLAND**

**FRANCE**

**GERMANY**

**ITALY**

**MEXICO**

**SWEDEN**

*Holidays Around The World*



# PASSPORT

*This passport states  
the carrier is a  
citizen of the world  
who learns about  
and respects the  
cultures of others.*



**Name** \_\_\_\_\_

**Country:** \_\_\_\_\_

**Birth Date** \_\_\_\_\_

**Hair Color** \_\_\_\_\_

**Eye Color** \_\_\_\_\_

**Issue Date** \_\_\_\_\_

**ENGLAND**

**GERMANY**

**HOLLAND**

**ITALY**

**MEXICO**

**SWEDEN**

*Holidays Around The World*



# PASSPORT

*This passport states  
the carrier is a  
citizen of the world  
who learns about  
and respects the  
cultures of others.*



**Name** \_\_\_\_\_

**Country:** \_\_\_\_\_

**Birth Date** \_\_\_\_\_

**Hair Color** \_\_\_\_\_

**Eye Color** \_\_\_\_\_

**Issue Date** \_\_\_\_\_

**ENGLAND**

**GERMANY**

**ISRAEL**

**ITALY**

**MEXICO**

**SWEDEN**

*Holidays Around The World*



# PASSPORT

*This passport states  
the carrier is a  
citizen of the world  
who learns about  
and respects the  
cultures of others.*



**Name** \_\_\_\_\_

**Country:** \_\_\_\_\_

**Birth Date** \_\_\_\_\_

**Hair Color** \_\_\_\_\_

**Eye Color** \_\_\_\_\_

**Issue Date** \_\_\_\_\_



*Holidays Around The World*



PASSPORT

*This passport states  
the carrier is a  
citizen of the world  
who learns about  
and respects the  
cultures of others.*



**Name** \_\_\_\_\_

**Country:** \_\_\_\_\_

**Birth Date** \_\_\_\_\_

**Hair Colour** \_\_\_\_\_

**Eye Colour** \_\_\_\_\_

**Issue Date** \_\_\_\_\_























# Trip Journal

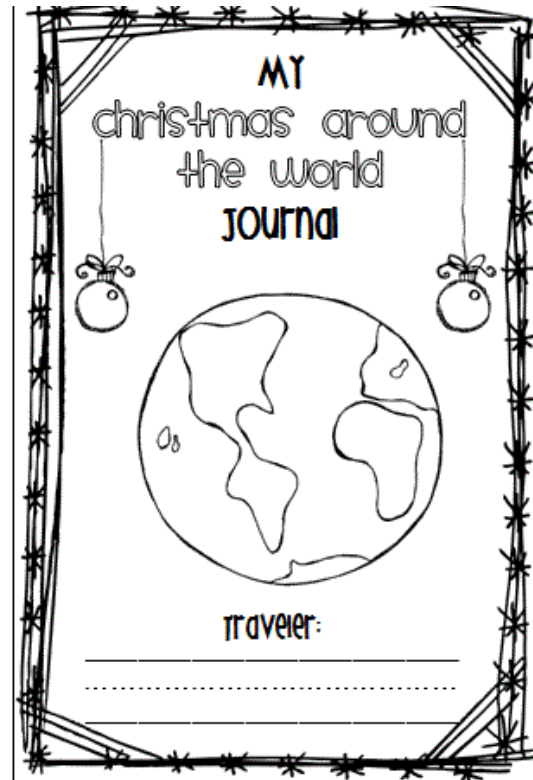

primary junction  
primaryjunction.blogspot.com

It is always a good idea to keep a journal/scrapbook of one's travels, and this trip around the world is no different.

Make a copy of the trip journal for each student. Included are two different templates: one with an entire page for writing (intended for older students) and one with sections for drawing and writing (intended for younger students). After each country visit, have students pull out their trip journal and write about where they visited and what they learned. This will not only allow students to practice their writing skills, it will also help them remember the Christmas traditions in each country and what each craft represents. Parents will love getting to read their child's journal as well!

primary junction

**MY**  
christmas around  
the world  
**JOURNAL**

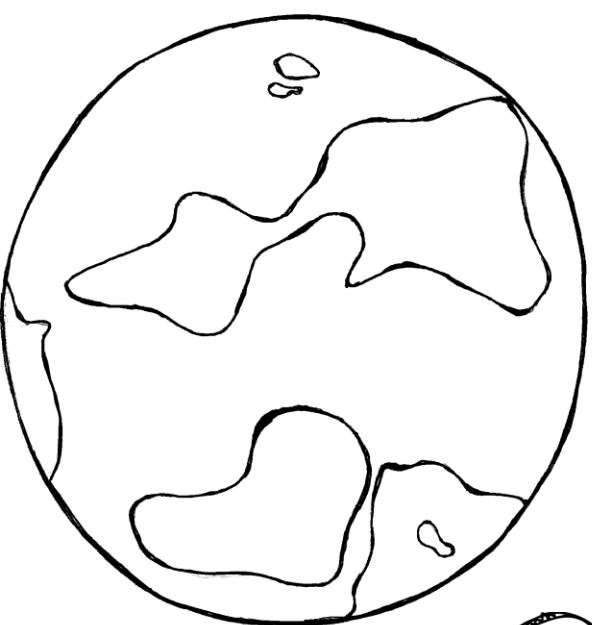

**TRAVELER:**

\_\_\_\_\_

\_\_\_\_\_

\_\_\_\_\_

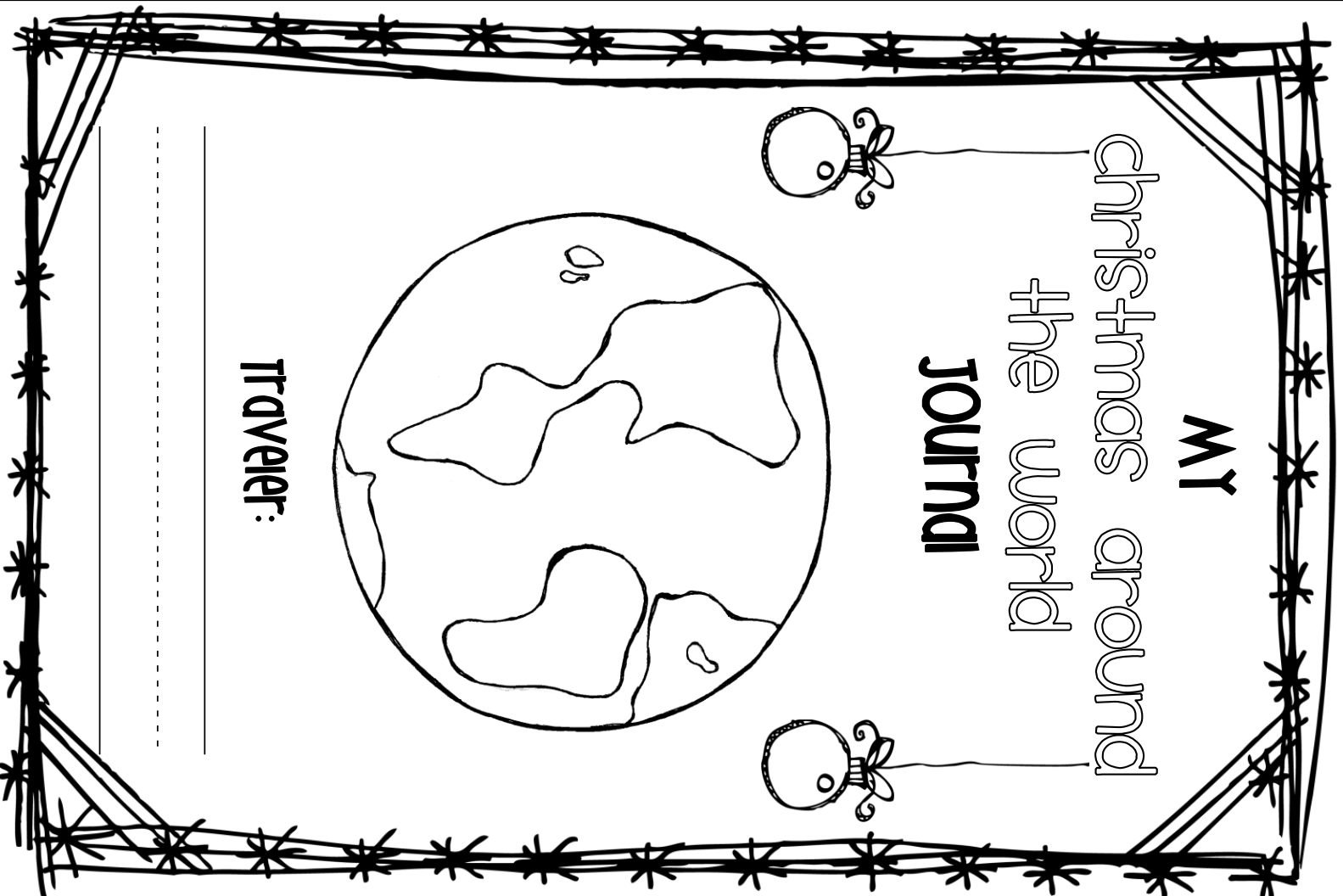

**MY**  
holidays around  
the world  
**JOURNAL**

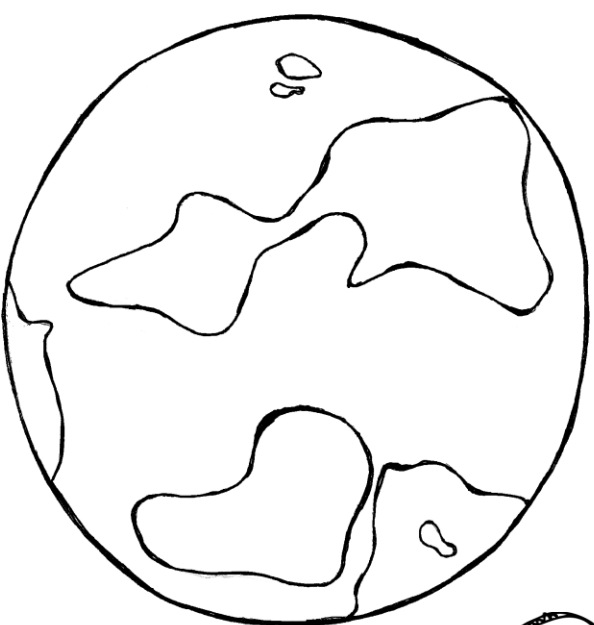

**TRAVELER:**

\_\_\_\_\_

\_\_\_\_\_

\_\_\_\_\_

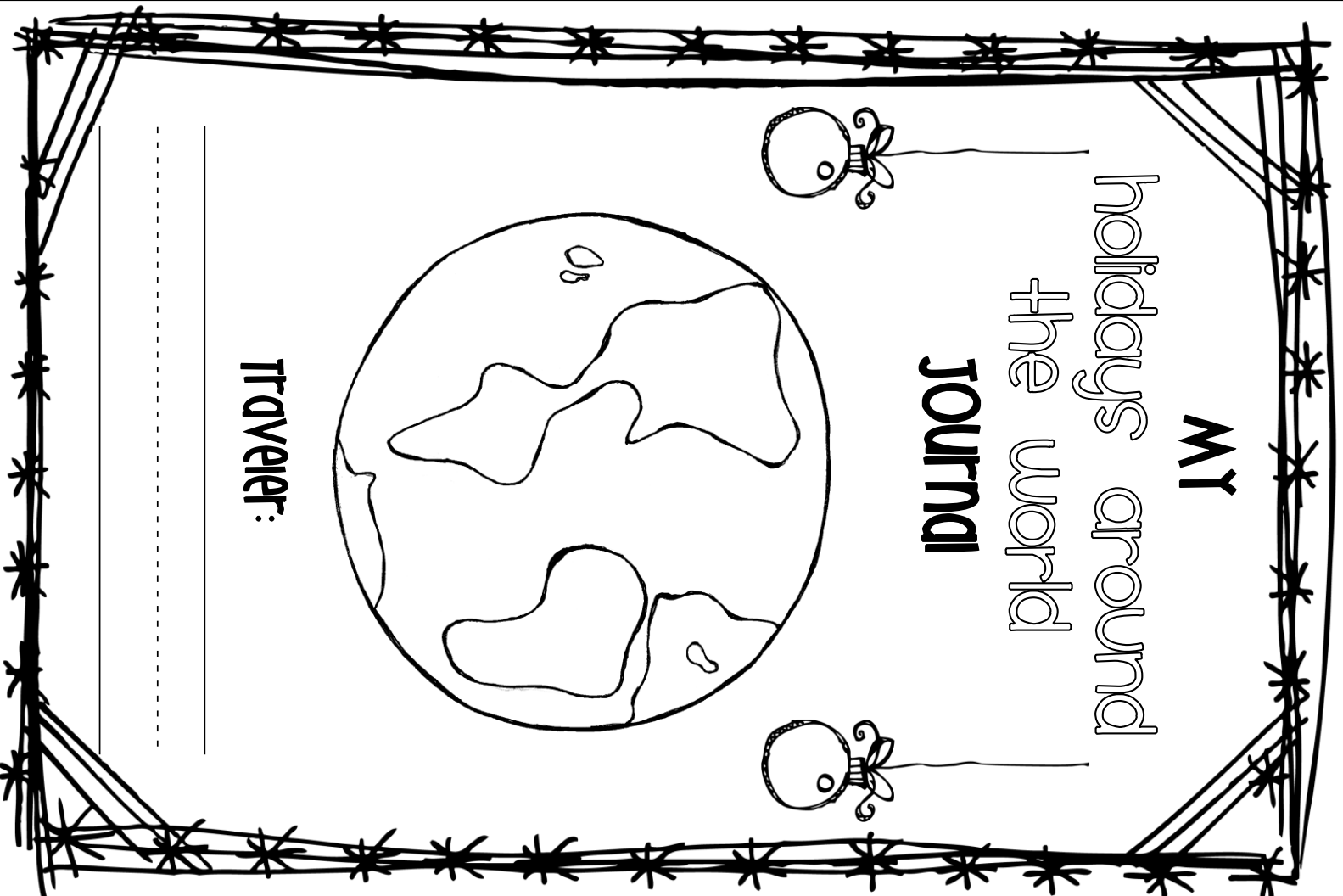

Date:

Date:

Date: . . .

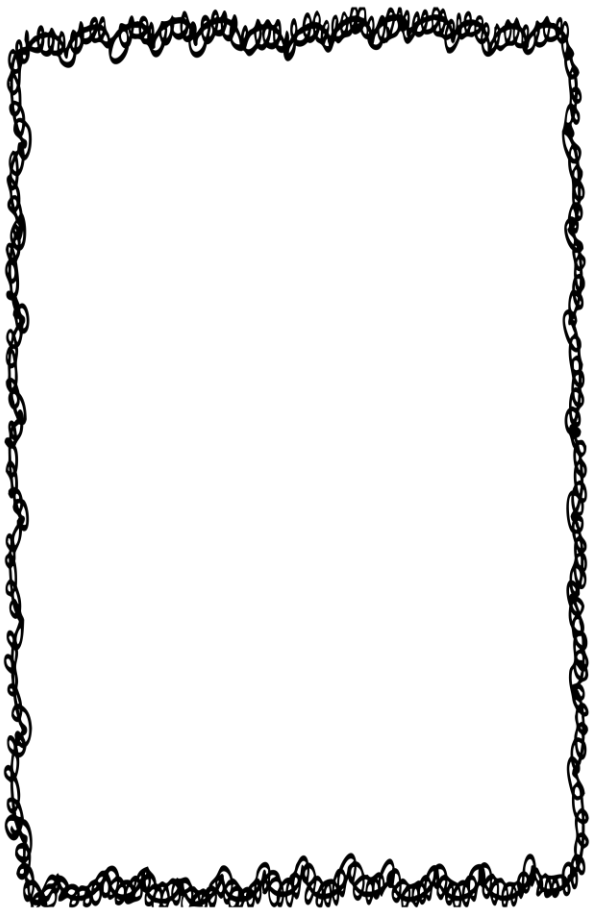

Handwriting practice lines consisting of a solid top line, a dashed middle line, and a solid bottom line, repeated four times.

Date: . . .

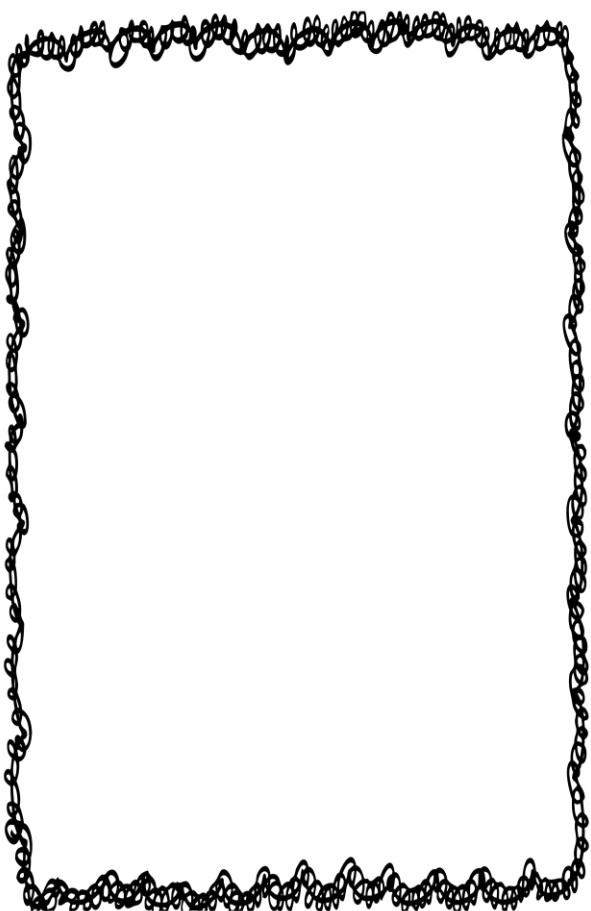

Handwriting practice lines consisting of a solid top line, a dashed middle line, and a solid bottom line, repeated four times.



# Trip Suitcase



Since this is a “trip around the world”, your students will need a suitcase to carry all of those goodies they will collect as they visit each country!

## Materials To Construct Suitcase (For Teacher):

- Four sheets of 12”x18” tan construction paper or two 12”x18” sheets of tan cardstock
- Copy of Suitcase Handles – 2 per side for durability (Use Cardstock for durability)
  - Copy of Tag
  - Hole Punch
  - Stapler

## Materials To Construct Suitcase (For Student):

- Copy of Map
- Glue Stick
- Crayons

# Trip Suitcase

## Teacher Instructions

The teacher will pre-make the suitcases.

1. Staple together four sheets of 12"x18" tan construction paper (two for each side – this makes the suitcase more sturdy) or two 12"x18" sheets of tan cardstock.
2. Next, staple two suitcase handles in each inside of the top of the suitcase.
3. Punch a hole into a tag and tie it onto one of the suitcase handles using a piece of yarn.



## Student Instructions

1. Prior to giving students their suitcases, give each student a world map and go over the countries they will be visiting. For each country they will be visiting, have them color it on their map and also write the name of the country. Students then glue the map to the front of their suitcase.
2. Finally, have students write their name on their tag and decorate both sides of their suitcase with Christmas drawings.



# SUITCASE HANDLES

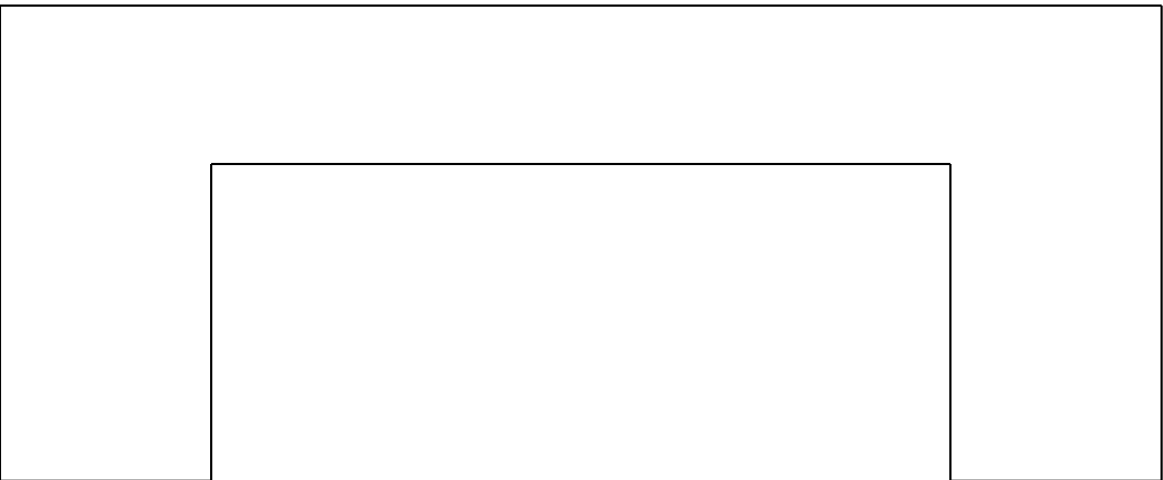
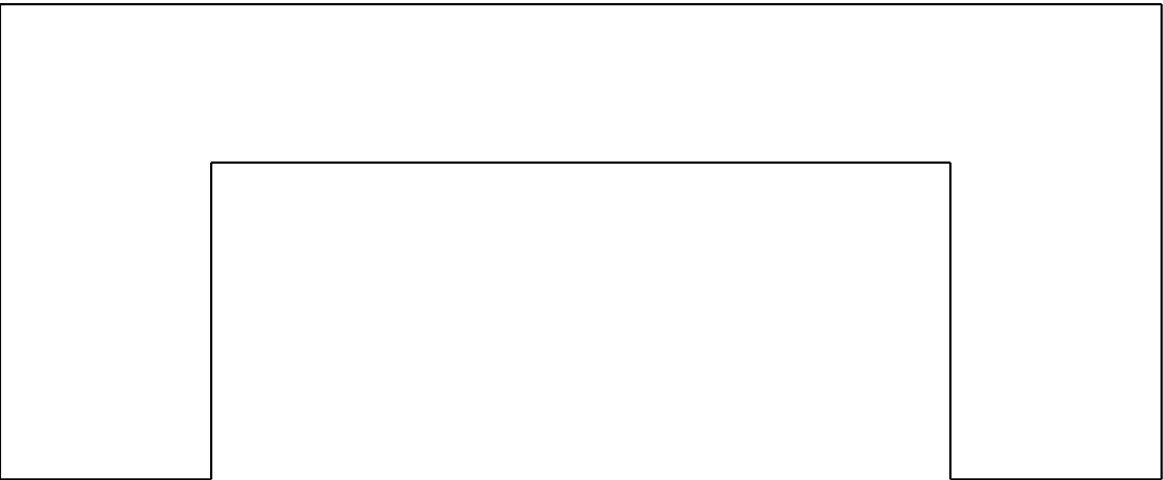
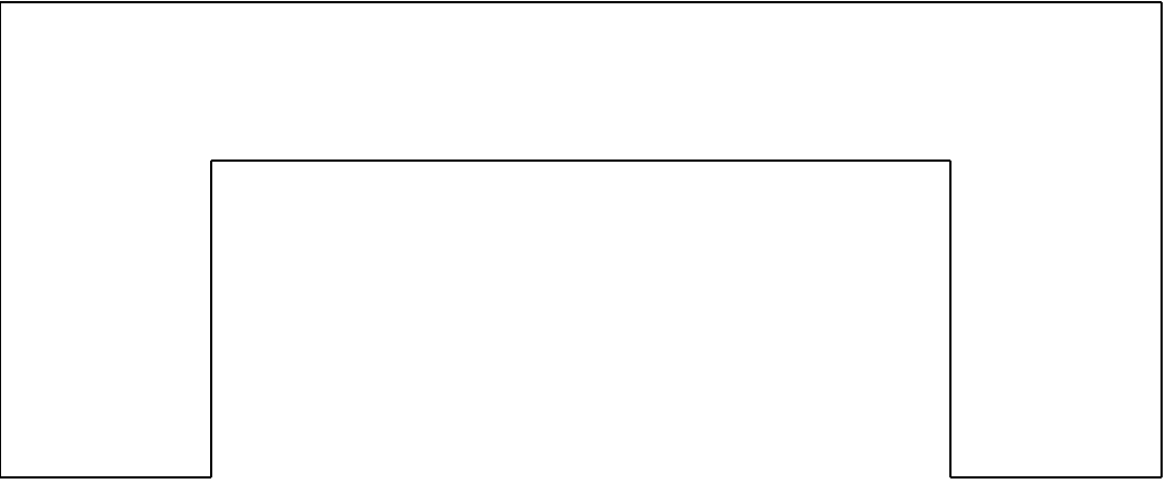
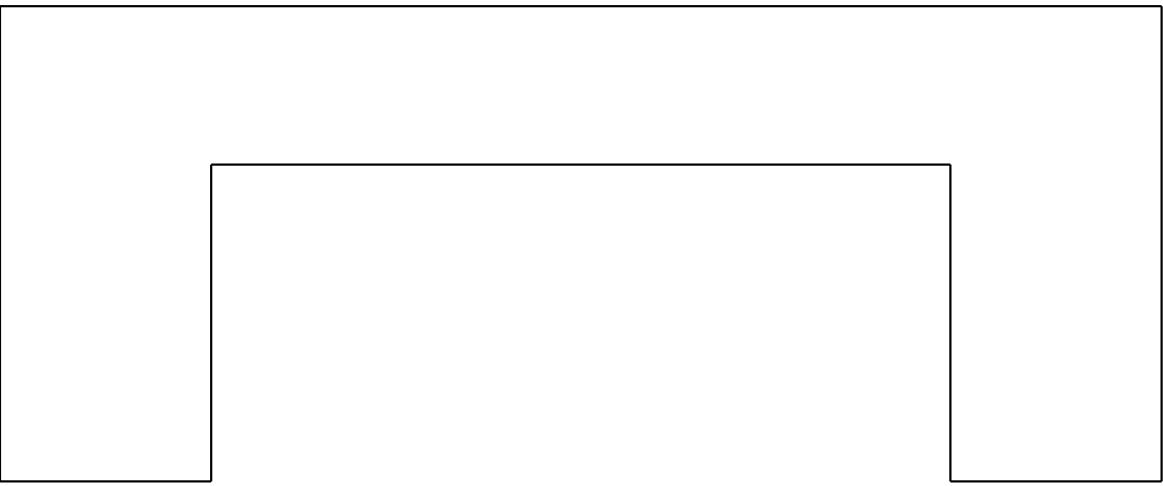

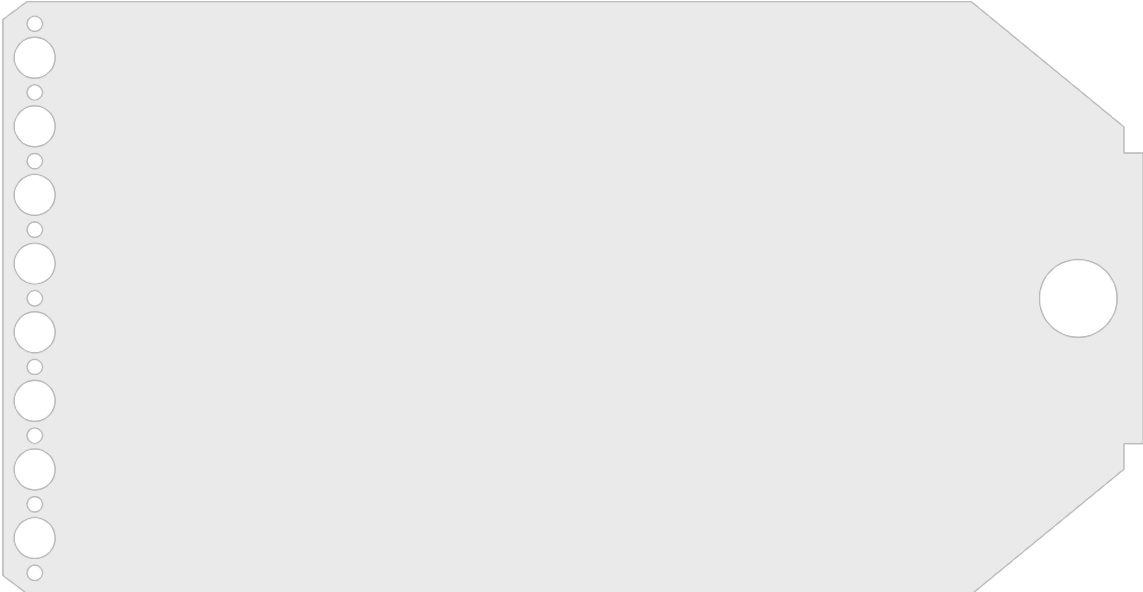
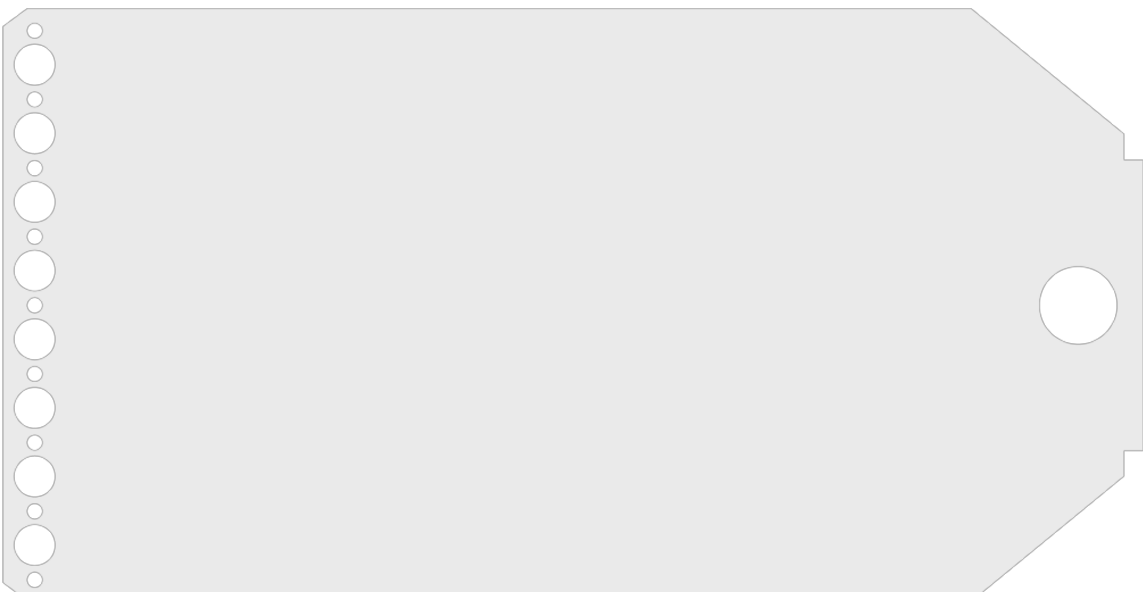
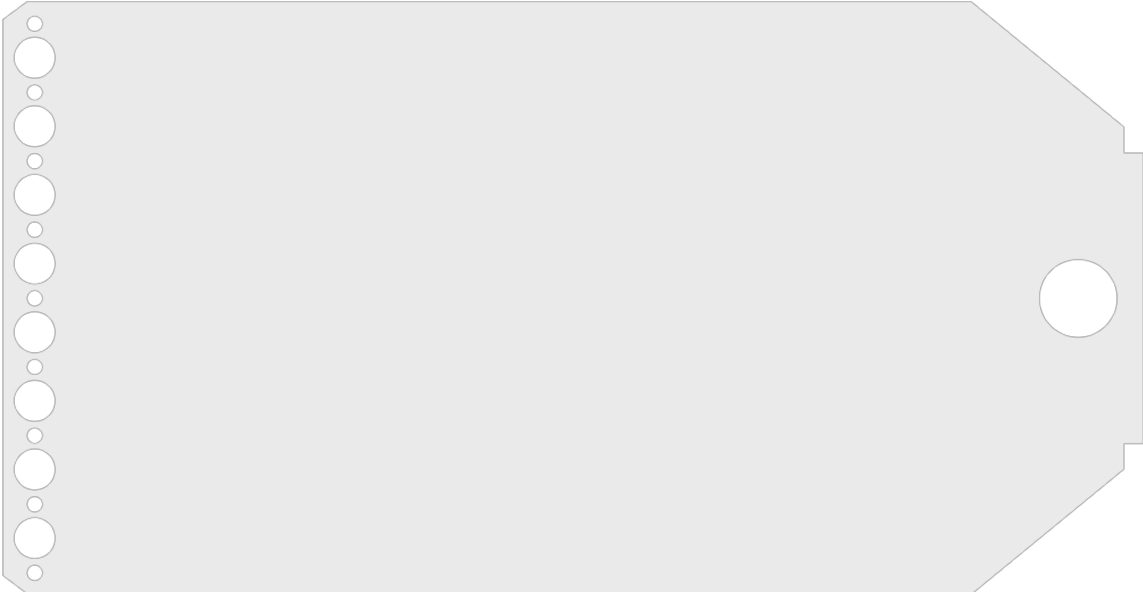

# S U I T C A S E T A G S

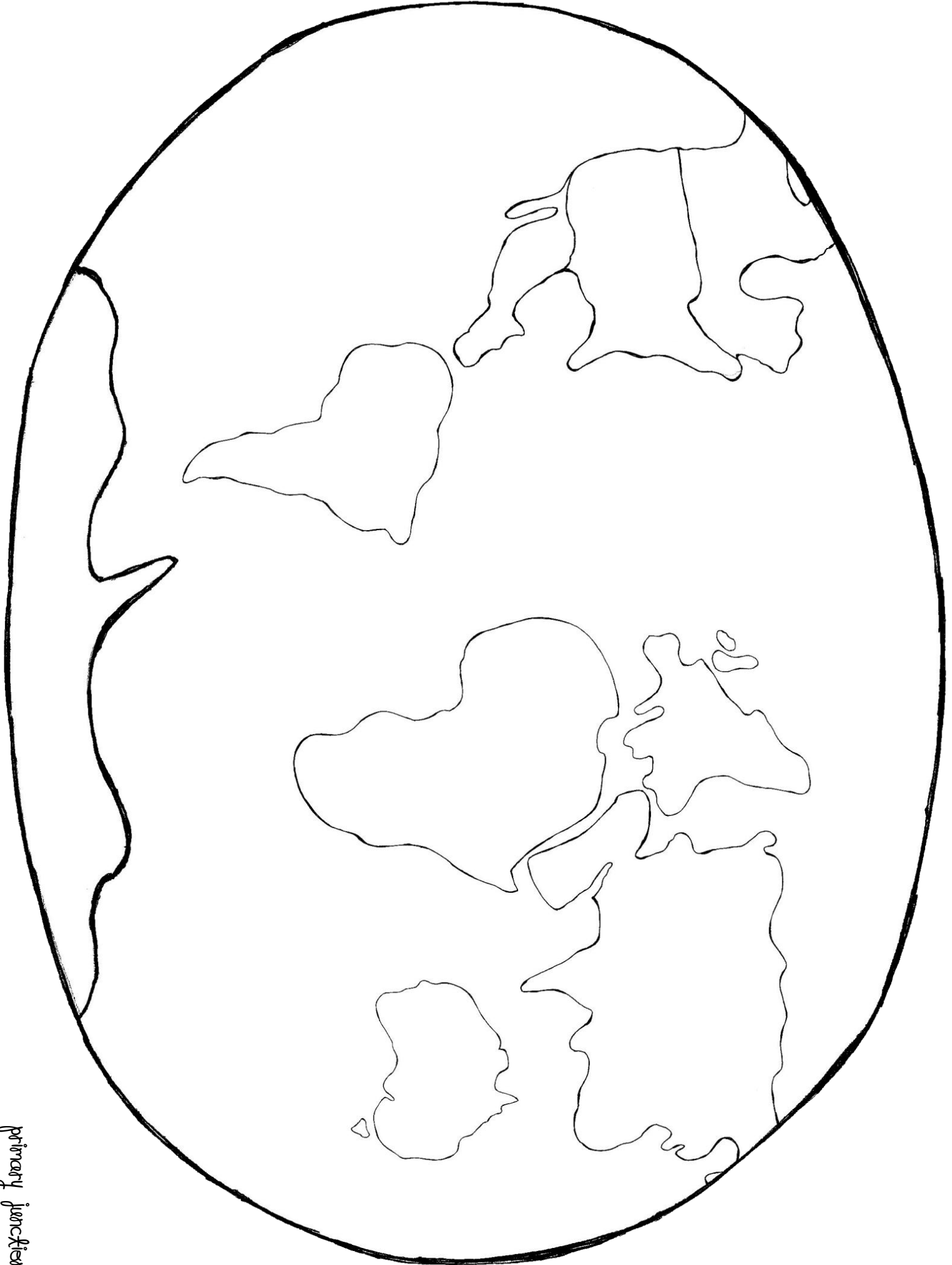



primary junction

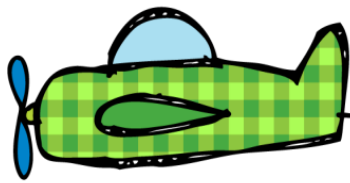

# CHRISTMAS AIRLINES

## Boarding Pass

Passenger Name \_\_\_\_\_

Flight Number \_\_\_\_\_

Flight Origin \_\_\_\_\_

Seat Number \_\_\_\_\_

Flight Destination \_\_\_\_\_

Departure Time \_\_\_\_\_

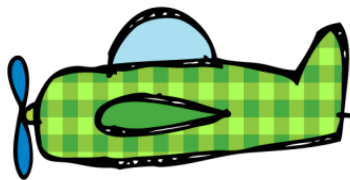

# CHRISTMAS AIRLINES

## Boarding Pass

Passenger Name \_\_\_\_\_

Flight Number \_\_\_\_\_

Flight Origin \_\_\_\_\_

Seat Number \_\_\_\_\_

Flight Destination \_\_\_\_\_

Departure Time \_\_\_\_\_

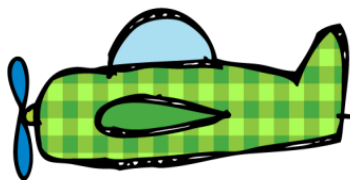

# CHRISTMAS AIRLINES

## Boarding Pass

Passenger Name \_\_\_\_\_

Flight Number \_\_\_\_\_

Flight Origin \_\_\_\_\_

Seat Number \_\_\_\_\_

Flight Destination \_\_\_\_\_

Departure Time \_\_\_\_\_



# CHRISTMAS AIRLINES

## Boarding Pass

Passenger Name \_\_\_\_\_

Flight Number \_\_\_\_\_

Flight Origin \_\_\_\_\_

Seat Number \_\_\_\_\_

Flight Destination \_\_\_\_\_

Departure Time \_\_\_\_\_



# CHRISTMAS AIRLINES

## Boarding Pass

Passenger Name \_\_\_\_\_

Flight Number \_\_\_\_\_

Flight Origin \_\_\_\_\_

Seat Number \_\_\_\_\_

Flight Destination \_\_\_\_\_

Departure Time \_\_\_\_\_



# CHRISTMAS AIRLINES

## Boarding Pass

Passenger Name \_\_\_\_\_

Flight Number \_\_\_\_\_

Flight Origin \_\_\_\_\_

Seat Number \_\_\_\_\_

Flight Destination \_\_\_\_\_

Departure Time \_\_\_\_\_



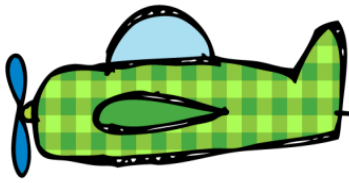

# HOLIDAY AIRLINES

## Boarding Pass

Passenger Name \_\_\_\_\_

Flight Number \_\_\_\_\_

Flight Origin \_\_\_\_\_

Seat Number \_\_\_\_\_

Flight Destination \_\_\_\_\_

Departure Time \_\_\_\_\_

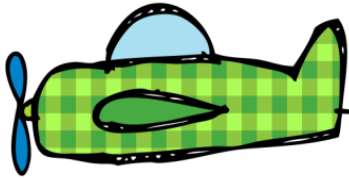

# HOLIDAY AIRLINES

## Boarding Pass

Passenger Name \_\_\_\_\_

Flight Number \_\_\_\_\_

Flight Origin \_\_\_\_\_

Seat Number \_\_\_\_\_

Flight Destination \_\_\_\_\_

Departure Time \_\_\_\_\_

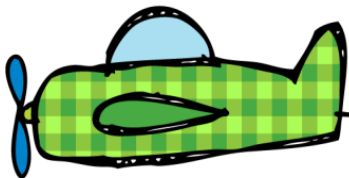

# HOLIDAY AIRLINES

## Boarding Pass

Passenger Name \_\_\_\_\_

Flight Number \_\_\_\_\_

Flight Origin \_\_\_\_\_

Seat Number \_\_\_\_\_

Flight Destination \_\_\_\_\_

Departure Time \_\_\_\_\_



# HOLIDAY AIRLINES

## Boarding Pass

Passenger Name \_\_\_\_\_

Flight Number \_\_\_\_\_

Flight Origin \_\_\_\_\_

Seat Number \_\_\_\_\_

Flight Destination \_\_\_\_\_

Departure Time \_\_\_\_\_



# HOLIDAY AIRLINES

## Boarding Pass

Passenger Name \_\_\_\_\_

Flight Number \_\_\_\_\_

Flight Origin \_\_\_\_\_

Seat Number \_\_\_\_\_

Flight Destination \_\_\_\_\_

Departure Time \_\_\_\_\_



# HOLIDAY AIRLINES

## Boarding Pass

Passenger Name \_\_\_\_\_

Flight Number \_\_\_\_\_

Flight Origin \_\_\_\_\_

Seat Number \_\_\_\_\_

Flight Destination \_\_\_\_\_

Departure Time \_\_\_\_\_

# book and music suggestions

## World



## China

[Jingle Bells in Chinese](#)

[Read About Christmas Traditions in China](#)

## England



[Christmas Traditions in England Video](#)

[Twelve Days of Christmas Video](#)

[Animated A Christmas Carol Movie](#)

[Read About Christmas Traditions in England](#)

## Ethiopia

[Read About Christmas Traditions in Ethiopia](#)

## France

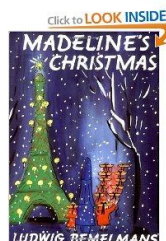

[The Christmas Song in French](#)

[Read About Christmas Traditions in France](#)

# book and music suggestions

## Germany



[O Christmas Tree Music Video](#)

[Read About Christmas Traditions in Germany](#)

## Holland

[Read About Christmas Traditions in Holland](#)

## Italy



[Read About Christmas Traditions in Italy](#)

## Israel

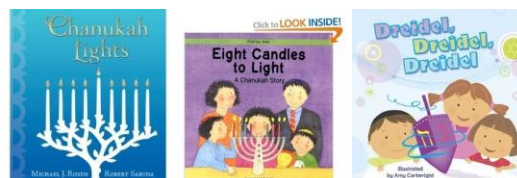

[The Dreidl Song Music Video](#)

[Read About Chanukah Traditions in Israel](#)

## Mexico



[Read About Christmas Traditions in Mexico](#)

# book and music suggestions

## Mexico

[Feliz Navidad Music Video](#)

[Jingle Bells Music Video](#)

[Silent Night Music Video](#)

## Sweden

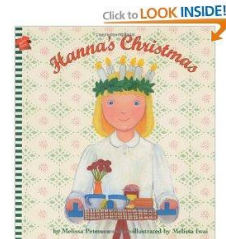
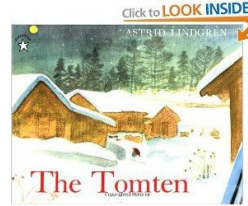
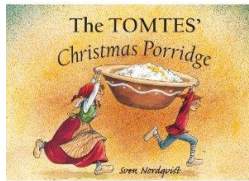
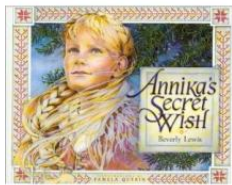

[Read About Christmas Traditions in Sweden](#)



# china



**Chinese Lantern**

**Purpose:** Only about one percent of the people in China are Christians, so most only know a few things about Christmas. Not every home will have a Christmas Tree (or even celebrate!). If people do have a tree it is normally a plastic one (it may be called 'A Tree of Light') and might be decorated with paper chains, paper flowers, and paper lanterns.

*\*For an extra culture experience, ask a local Chinese restaurant if they would be interested in donating fortune cookies, chopsticks, and a sample of Chinese food for the kids to try. You can also purchase these items for cheap from Oriental Trading if needed and add to a small Chinese noodle sample.*

## **Materials:**

- 8"x11" Sheet of Red Construction Paper
- Scissors
- Stapler

## **Procedures:**

1. Fold the sheet of construction paper in half, hot-dog style. Open the sheet.
2. Cut off a small strip off of the bottom of the sheet of paper. Put this aside.
3. Fold the larger sheet again along the crease.
4. On the closed side (along the crease) cut slits about 2-3 centimeters apart, almost all the way to the other side.
5. Open the sheet up and fold hamburger--style. Staple or tape both sides together.
6. Finally, tape or staple the small slit of paper cut earlier to the inside of the lantern to make a handle.

primary junction

# chinese paper lantern

## photo instructions

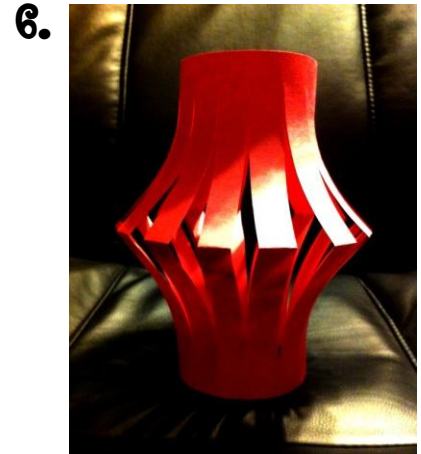
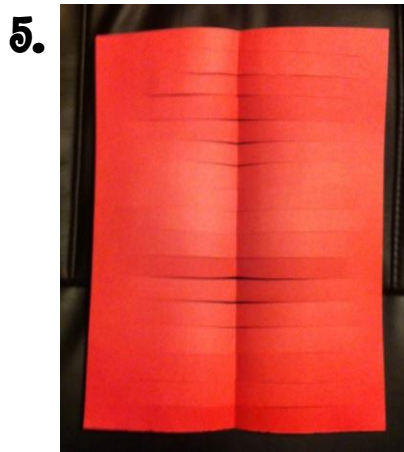
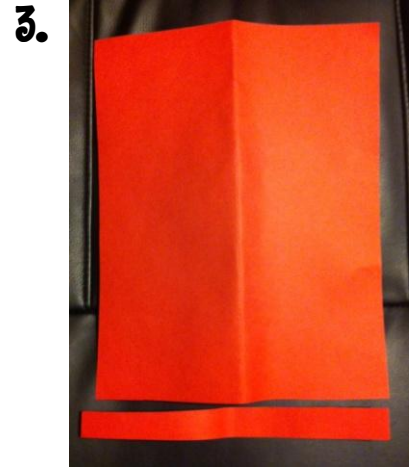
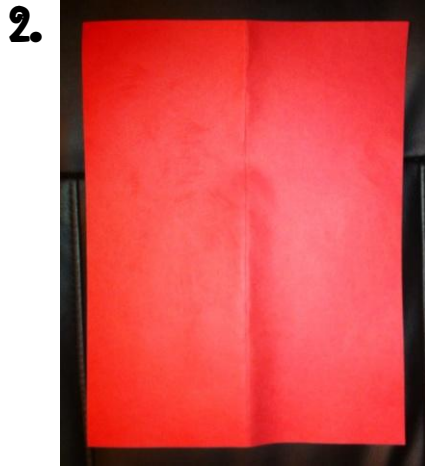

In China you would see Christmas decorations mainly in big cities such as Beijing and Shanghai.

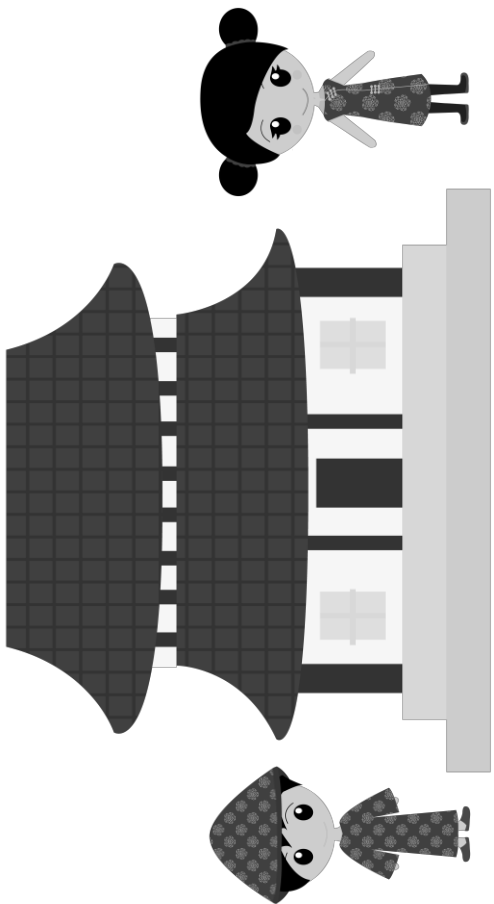

More people live in China than anywhere else, but only a few celebrate Christmas.



## Christmas in China

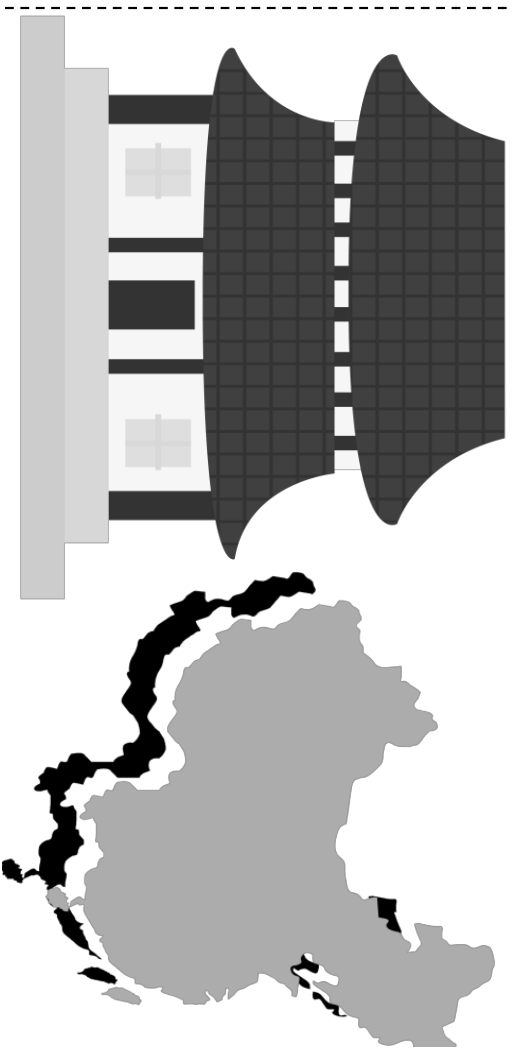

A Christmas Tree is called A Tree of Light in China. Paper chains, paper flowers, and paper lanterns are used as decorations.

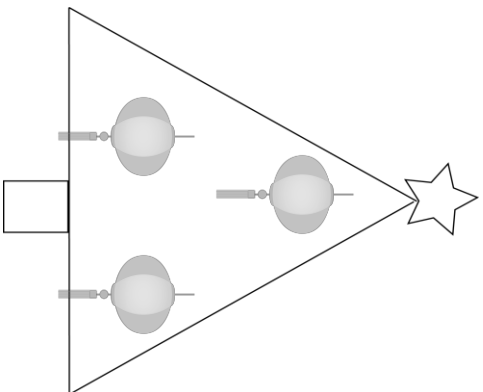



# China

NAME \_\_\_\_\_

## PEOPLE'S REPUBLIC OF CHINA

Where in the world  
is China?

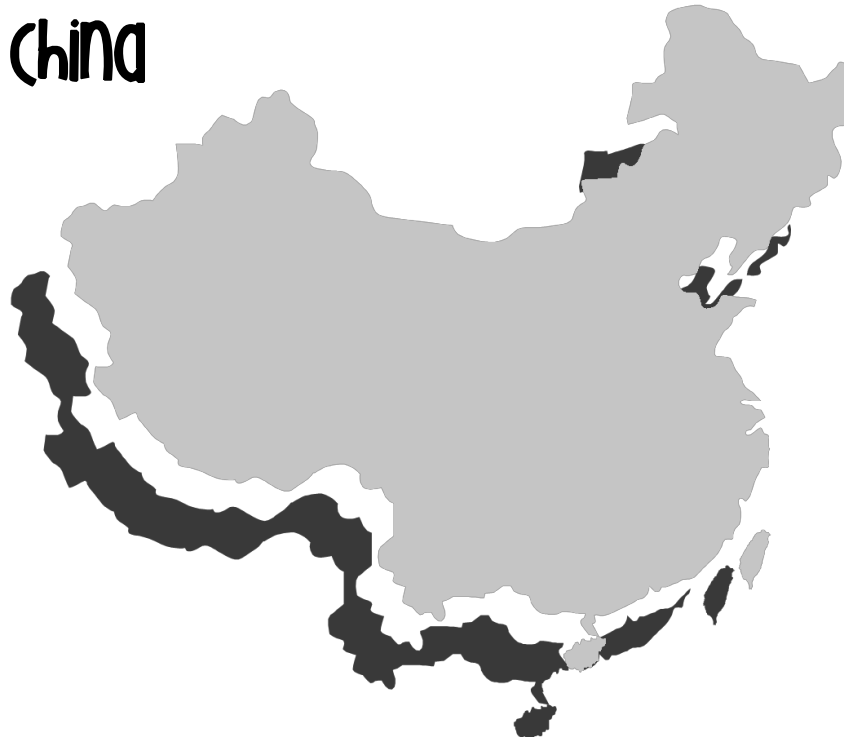
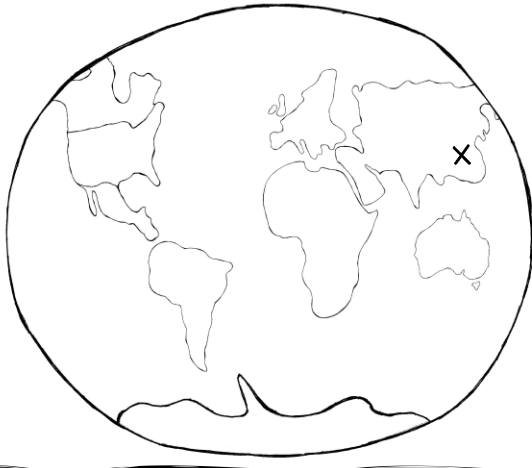

Although more people (1.3 billion) call China home than anywhere else in the world, only about 13 million celebrate Christmas. Most people in China know very little about the holiday.

If you were to visit China around Christmas, you would probably only see Christmas decorations in big cities such as Beijing and Shanghai. Many stores and streets in those areas are decorated.

Not every home in China will have a Christmas Tree or even celebrate. If they do have a tree, it is usually an artificial one and is called 'A Tree of Light'. Trees might be decorated with paper chains, paper flowers, and paper lanterns.

The most popular winter holiday in China is Chinese New Year. It celebrates the end of winter and is usually around February. It ends with the Lantern Festival. Many children make paper lanterns at this time.

It is a special time of year for those in China who celebrate.

# China Reading Check

- Another good title for this story might be:  
A) Christmas      B) Celebrating Christmas in China      C) A Tree of Light
- How many people in China celebrate Christmas?  
A) 13 million      B) 1.3 billion      C) 13 people
- What are Christmas trees called in China?  
A) Christmas Tree      B) Paper Lantern      C) A Tree of Light
- What is the author's purpose in writing this article?  
A) To teach us  
B) To tell us a funny story  
C) To try to make us do something
- What type of tree can be found in most homes in China?  
A) Real      B) Artificial      C) Light
- What is the second paragraph mainly about?  
A) Christmas Trees      B) How many people are in China      C) Decorations
- In what China cities might you see Christmas decorations?  
\_\_\_\_\_  
\_\_\_\_\_
- What was this article mainly about?  
\_\_\_\_\_  
\_\_\_\_\_
- What will you most likely NOT find on A Tree of Light in China?  
A) Paper Lantern      B) Tinsel      C) Paper Chains
- What types of items might you see on A Tree of Light in China?  
\_\_\_\_\_  
\_\_\_\_\_  
\_\_\_\_\_  
\_\_\_\_\_

# China

NAME \_\_\_\_\_

## PEOPLE'S REPUBLIC OF CHINA

Where in the world  
is China?

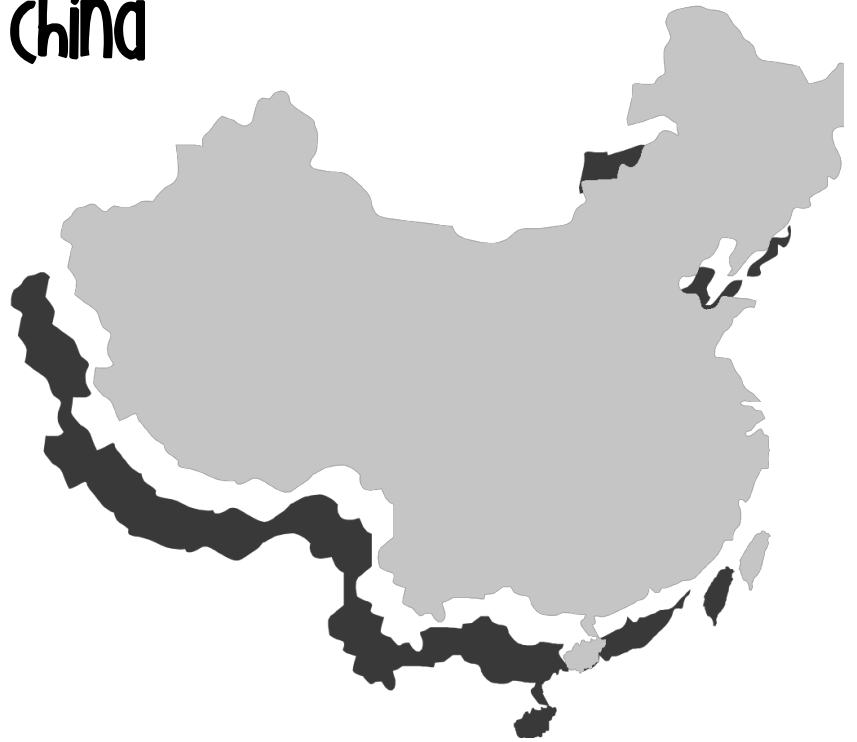
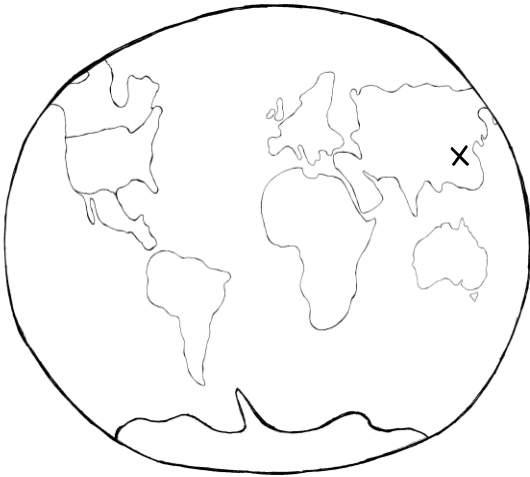

Although China, officially known as the People's Republic of China, is the world's most populous country with 1.3 billion people, only about one percent (13 million) of the people in China are Christians. Therefore, most only know a few things about Christmas.

If you were to visit China around Christmas, you would probably only see Christmas decorations in major cities such as Beijing and Shanghai. Many department stores and streets in those areas are decorated. In China, not every home will have a Christmas Tree or even celebrate. If they do have a tree, it is normally an artificial one and is often called 'A Tree of Light'. Trees might be decorated with paper chains, paper flowers, and paper lanterns.

Through the years another tradition that has been catching on is giving loved ones apples wrapped in colored paper. In China, Christmas Eve is called 'Ping An Ye', which means silent night. So what does this have to do with apples? Well, in Chinese, apple is 'Ping Guo', which sounds very similar, and as a result, many people in China give apples to others on Christmas Eve.

The most popular winter holiday in China is Chinese New Year. It celebrates the end of winter and is usually around February. It ends with the Lantern Festival. Many children make paper lanterns at this time.

Although China may not have many Christmas traditions, the ones they do have are very special.

# China Reading Check

1. How many people in China celebrate Christmas?

- A) 13 million                      B) 1.3 billion                      C) 13 people

4. What is the author's purpose in writing this article?

- A) To inform                      B) To persuade                      C) To entertain

3. What is the official name of China?

---

---

---

4. What will you most likely NOT find on A Tree of Light in China?

- A) Paper Lantern                      B) Tinsel                      C) Paper Chains

5. What is the population of China?

- A) 13 million                      B) 1.3 billion                      C) 1.3 million

6. What is the Chinese term for Christmas Eve?

- A) Ping Guo                      B) Ping An Ye                      C) Ping Guo Ye

7. How is a Christmas Tree in China both alike and different from one in your home?

---

---

---

---

---

8. Another good title for this story might be:

- A) Christmas                      B) Celebrating Christmas in China                      C) A Tree of Light

9. Why do some people in China give apples as gifts on Christmas Eve?

---

---

---

10. Why do you think Beijing and Shanghai have the most Christmas decorations?

---

---

---

Welcome To

China

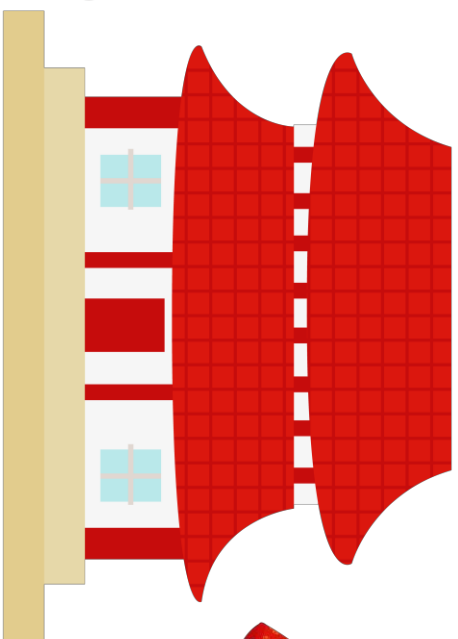
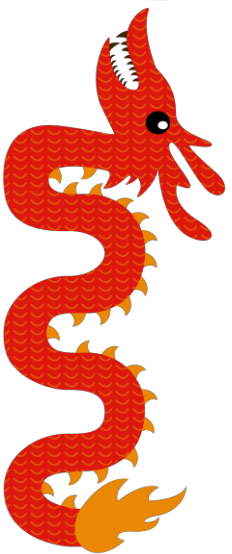
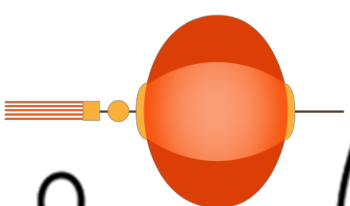
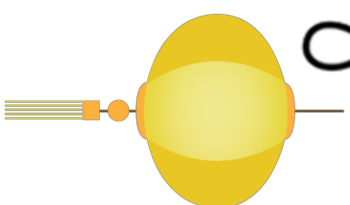
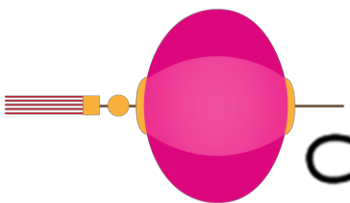
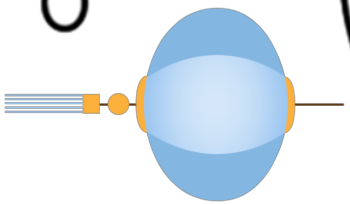

Ni hao

means "Hello"  
Pronounced knee-how

# england



**Christmas Cracker**

**Purpose:** Christmas crackers are pulled at a Christmas dinner table or party. Each person will have their own cracker and will keep its contents. Included contents are usually a colored paper hat or crown; a small toy, small trinket, and a joke, riddle or piece of trivia on a small strip of paper.

### **Materials:**

- Toilet Paper Tube (Can use for each cracker or just as a guide)
- Colored tissue paper (One sheet should make two)
- Ribbon
- Contents Per Cracker: a small toy, a small piece of wrapped candy, a small ornament, and a joke or piece of trivia

### **Procedures:**

1. Depending on the number of students you have, you may want to pre-make these or begin pre-making them.
2. Wrap tissue paper around toilet paper tube and twist ends.
3. Secure one end of tissue paper with ribbon. Leave the other open to place the cracker contents.
4. Depending on how many toilet paper tubes and students you have, you might find it best to remove the tube at this point after using it as a guide or simply leaving it. Leaving it will make the cracker look nicer but will also most likely stay intact when the cracker is pulled apart.

# england continued...



Christmas Cracker

5. Place contents inside. You could also have a table set up with content sections and have students place contents inside. If you choose to do this, students can make a cracker for a classmate or a student in another grade (if you switch classes while traveling, you could change out contents for each class to make it a surprise!
6. Once all contents are placed, twist the other end of the tube and secure with ribbon.
7. To make the opening more of a surprise, I always take up the crackers once they are completed and randomly pass them back out. The best option, in my experience, is to have a different classes make the crackers, so when students open theirs, they are surprised. You can decide to have students wait until they are home to open or open them in class. In class, students can open theirs individually, with a partner holding on end, or by having the entire class form a circle and crisscross hands and pull at the same time.

# christmas cracker jokes

**Q:** What did the gum say to the shoe?

**A:** I'm stuck on you!

**Q:** Why don't skeletons fight each other?

**A:** They don't have the guts!

**Q:** Why did the banana go to the doctor?

**A:** It wasn't peeling well.

**Q:** What stays in a corner and travels the world?

**A:** A Stamp.

**Q:** What does the letter A have in common with a flower?

**A:** They both have B's (bees) coming after them!

**Q:** What did the water say to the boat?

**A:** Nothing, it just waved.

**Q:** Why did the pony have to stay out of school?

**A:** For horsing around.

**Q:** Where did the cow go during the weekend?

**A:** To the moooovies.

**Q:** Why was the broom late?

**A:** It over swept!

**Q:** What kind of hair do oceans have?

**A:** Wavy!



# christmas cracker christmas-themed jokes

**Q:** Where does a snowman keep his money?

**A:** In a snow bank!

**Q:** Who says "Oh, Oh, Oh"?

**A:** Santa walking backwards!

**Q:** What do snowmen eat for breakfast?

**A:** Frosted Flakes.

**Q:** What do elves learn in school?

**A:** The elf-abet!

**Q:** What did the Christmas Tree say to the ornament?

**A:** "Aren't you tired of hanging around?"

**Q:** What do you call an old snowman?

**A:** Water!

**Q:** When does Christmas come before Thanksgiving?

**A:** In the dictionary!

**Q:** What do you have in December that you don't have in any other month?

**A:** The letter D.

**Q:** What often falls at the North Pole but never gets hurt?

**A:** Snow!

**Q:** What do you get if you cross an apple with a Christmas Tree?

**A:** A pineapple!

# christmas cracker trivia pieces

Did you know Giraffes can go without water longer than a camel?

Did you know for a butterfly to fly it must have a body temperature of no less than 86 degrees Fahrenheit?

Did you know the average human with a full head of hair contains between 85,000 to 150,000 hairs?

Did you know the tallest girl in the world ever recorded was 8 feet 2 inches tall and died at the age of 17?

Did you know Jupiter is the largest planet in the earths solar system?

Did you know cold weather makes fingernails grow faster?

Did you know it takes about 7 minutes for the average person to fall asleep?

Did you know that four out of five people over 100 years old are women?

Did you know a cat's ear has a total of thirty two muscles?

Did you know most people laugh 15 times a day?

# christmas cracker trivia pieces

Did you know the eye of an ostrich is larger than it's brain?

Did you know snails can sleep for up to three years?

Did you know that you can not fold a piece of notebook paper more than seven times?

Did you know that on December 16th 1811 the mighty Mississippi river began to flow backwards due to a powerful earthquake?

Did you know that when Orcas, also known as Killer Wales, travel in groups, they all breathe at the same time?

Did you know more people are killed yearly by donkeys than airplane crashes?

Did you know that most kids in Russia have a Birthday Pie, not a Birthday Cake?

Did you know there are over 200 different types of watermelon?

Did you know there are over 500,000 known earthquakes each year?

Did you know there are about 6,800 languages in the world?

An English Christmas meal includes turkey, mince pie, and Christmas pudding.

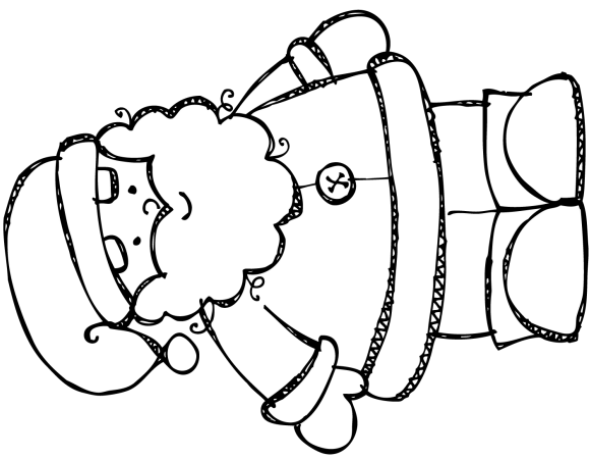

Children in England call Santa Claus Father Christmas.

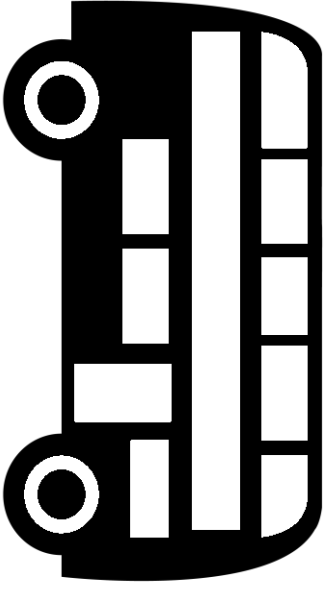

Christmas in England

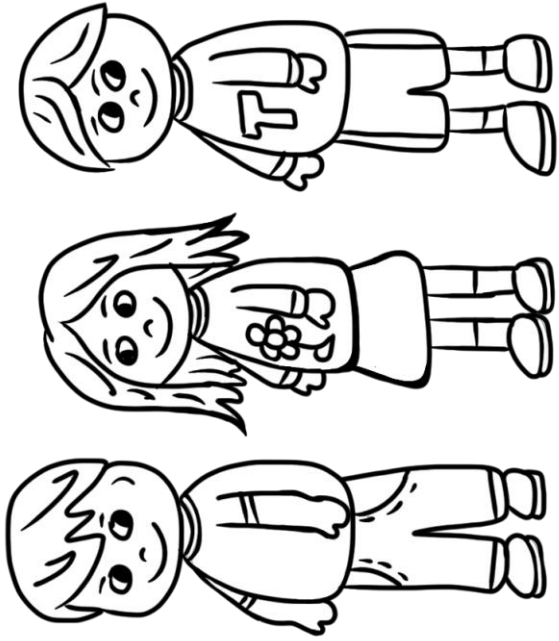

Christmas in England is a time for families.



's Book

# ENGLAND

NAME \_\_\_\_\_

Where in the world is  
England?

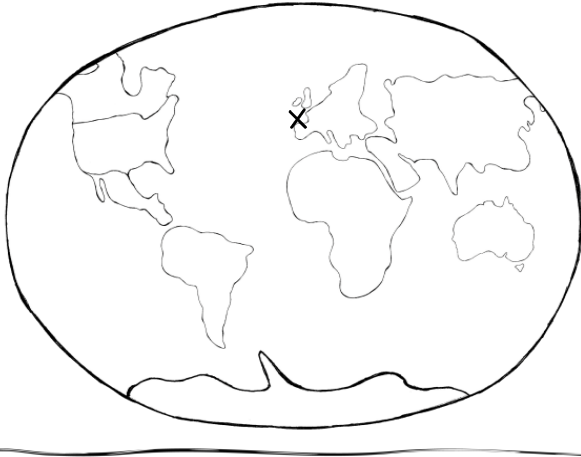

Christmas in England is a special time for families. They enjoy dinners, going to church, and giving gifts.

Christmas trees are in most homes. Some may have more than one. Families like to decorate the tree together.

Children in England call Santa Claus Father Christmas. Before Christmas they write him a letter. Children send him the letter by mail or by putting it into a fireplace.

The smoke from the fire carries the letter up the chimney and to Father Christmas.

Children also hang stockings by their bed or fireplace for Father Christmas to leave small gifts in. Many children also leave him a mince pie to eat on Christmas Eve.

On Christmas Day families meet for a Christmas meal. They might eat roast beef or turkey, roast vegetables, and stuffing. Desserts might be mince pie, Christmas pudding, or chocolates! Also at the dinner table are Christmas Crackers. In each cracker is a small toy, piece of candy, and a joke or riddle. When opened, the crackers make a sound.

The day after Christmas is Boxing Day. Families may give to the poor, shop, or watch horse meets and football games.

Christmas is a very special time of year for families in England.

# ENGLAND READING CHECK

1. What do children in England call Santa Claus?  
A) Santa Claus                      B) Mr. Christmas                      C) Father Christmas
2. The day after Christmas in England is known as \_\_\_\_\_?  
A) Christmas Eve                      B) Christmas                      C) Boxing Day
3. What food dish would you NOT find at a Christmas Meal in England?  
A) Roast Beef                      B) Turkey                      C) Pumpkin Pie
4. What is the author's purpose in writing this article?  
A) To teach us  
B) To tell us a story  
C) To try to make us do something
5. What might families do on Boxing Day?  
A) Watch a boxing match                      B) Watch a horse meet                      C) Buy boxes
6. Children might place their letter to Father Christmas in a \_\_\_\_\_?  
A) Fireplace                      B) Book                      C) Box
7. Which English Christmas activity would you most like to participate in?  
\_\_\_\_\_  
.....  
\_\_\_\_\_
8. What was this article mainly about?  
\_\_\_\_\_  
.....  
\_\_\_\_\_
9. Which Christmas Eve treat do children leave for Father Christmas?  
A) Christmas Pudding                      B) Mince Pie                      C) Roast Beef
10. Are there any English Christmas traditions you also do at home? If so, which?  
\_\_\_\_\_  
.....  
\_\_\_\_\_  
.....  
\_\_\_\_\_

# ENGLAND

NAME \_\_\_\_\_

Where in the world is  
England?

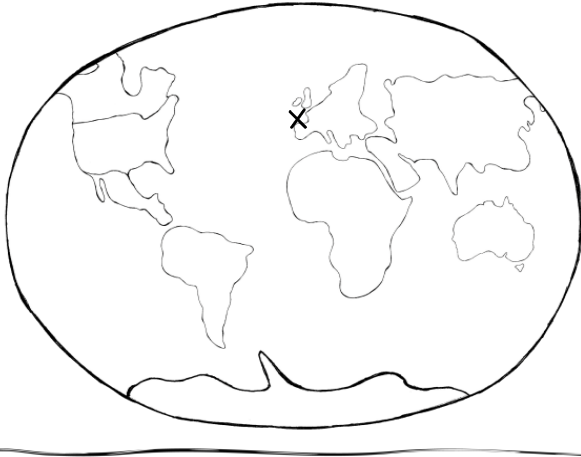

Christmas in England is a time for families. Families enjoy meals, attending nativity plays and church services, and exchanging gifts.

Christmas trees are in most homes in England. Some may have more than one. Families like to decorate the tree together. They also like to decorate their home with holly and mistletoe.

Children in England call Santa Claus Father Christmas. Before Christmas they write him a letter to let him know what they would like. Children send him the letter through the mail or by placing it into a lit fireplace. The smoke from the fire carries their message up the chimney and to Father Christmas who reads their letter through the smoke. Children also hang stockings by their bed or fireplace for Father Christmas to leave small gifts in. Many children also leave him a mince pie to eat during his visit on Christmas Eve.

On Christmas Day, families meet for a Christmas Meal, which usually consists of roast beef or turkey, as well as roast vegetables and stuffing. Desserts may include mince pie, Christmas pudding, and chocolates! Also at the dinner table are Christmas Crackers. Inside each cracker is a small toy, piece of candy, and a joke or riddle. When opened, the crackers make a crackling sound.

The day after Christmas is known as Boxing Day. On this day, families may give to the poor, and businesses may give to their employees. Many in England shop on this day thanks to good sales, while others attend or watch horse meets and football games.

Christmas is definitely a special time of year for families in England.

# ENGLAND READING CHECK

1. What do children in England call Santa Claus?  
A) Santa Claus                      B) Mr. Christmas                      C) Father Christmas
2. What is paragraph four mainly about?  
A) Father Christmas                      B) Christmas Meal                      C) Boxing Day
3. What food dish would you NOT find at a Christmas meal in England?  
A) Roast Beef                      B) Turkey                      C) Pumpkin Pie
4. What is the author's purpose in writing this article?  
A) To teach us  
B) To tell us a funny story  
C) To try to make us do something
5. What might families do on Boxing Day?  
A) Watch a boxing match                      B) Watch a horse meet                      C) Buy boxes
6. Children might place their letter to Father Christmas in a \_\_\_\_\_?  
A) Fireplace                      B) Book                      C) Box
7. Which English Christmas activity would you most like to participate in?  
\_\_\_\_\_  
\_\_\_\_\_
8. What was this article mainly about?  
\_\_\_\_\_  
\_\_\_\_\_
9. Which Christmas Eve treat do children leave for Father Christmas?  
A) Christmas Pudding                      B) Mince Pie                      C) Roast Beef

10. Describe how children in England send letters to Father Christmas.  
\_\_\_\_\_  
\_\_\_\_\_  
\_\_\_\_\_



# Welcome to England

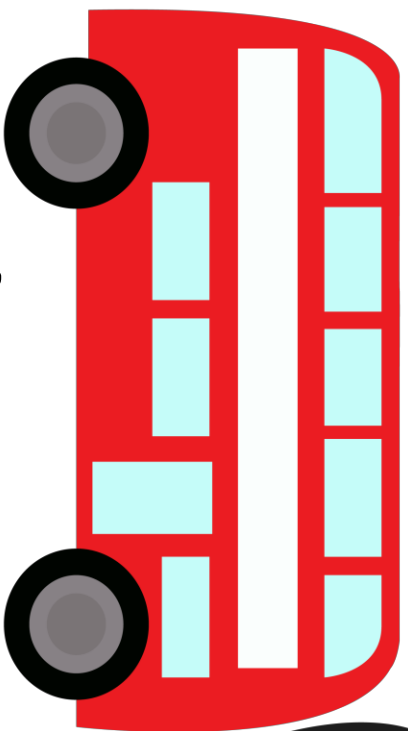
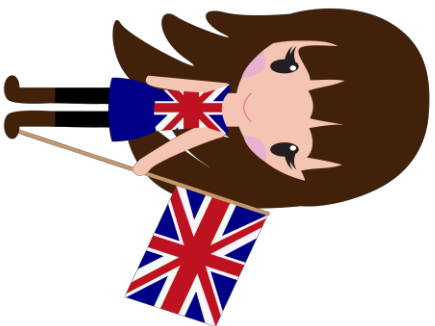

Hello



means "Hello"  
Pronounced hello

# Welcome To England

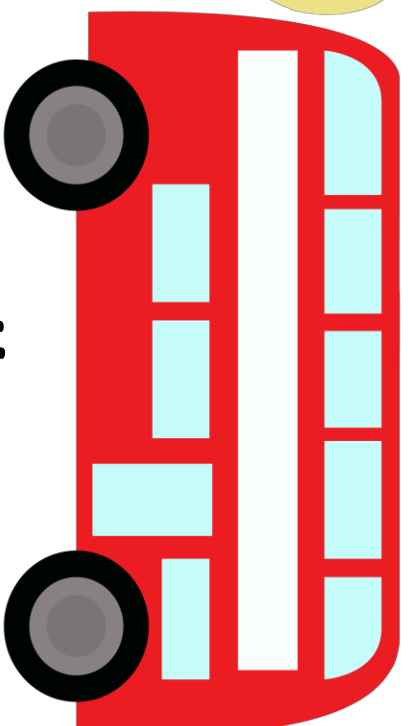
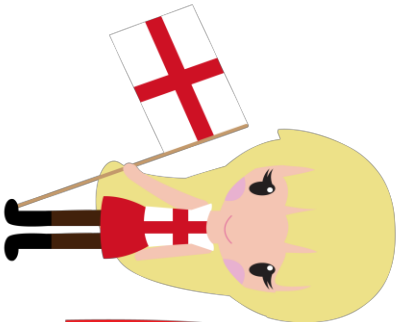

Hello

means "Hello"

Pronounced hello

# Ethiopia



**Ethiopian Drum**

**Purpose:** Ethiopia celebrates Christmas, which they call Ganna, on January 7. Twelve days later, on January 19, the Timkat celebration begins, which lasts three days. Timkat celebrates the baptism of Jesus. Children, wearing crowns and robes of the church youth groups they belong to, walk to church services in a procession and play musical instruments. During the celebrations of Ganna and Timkat, presents are not given or received; instead, it is a time for church services, eating, and playing games.

## **Materials:**

- Plastic Cup
- Rubber Band
- Sheet of Wax Paper
  - Dry Beans
  - Markers

## **Procedures:**

1. Give each child a plastic cup and piece of wax paper to decorate.
2. Fill each child's cup with just enough dry beans to cover the bottom of the cup.
3. Instruct students to place the wax paper over the top of the cup and secure with a rubber band.
4. Now, students can shake their 'drums' and celebrate!

No presents are given during Ganna or Timkat. It is a time for family and church.

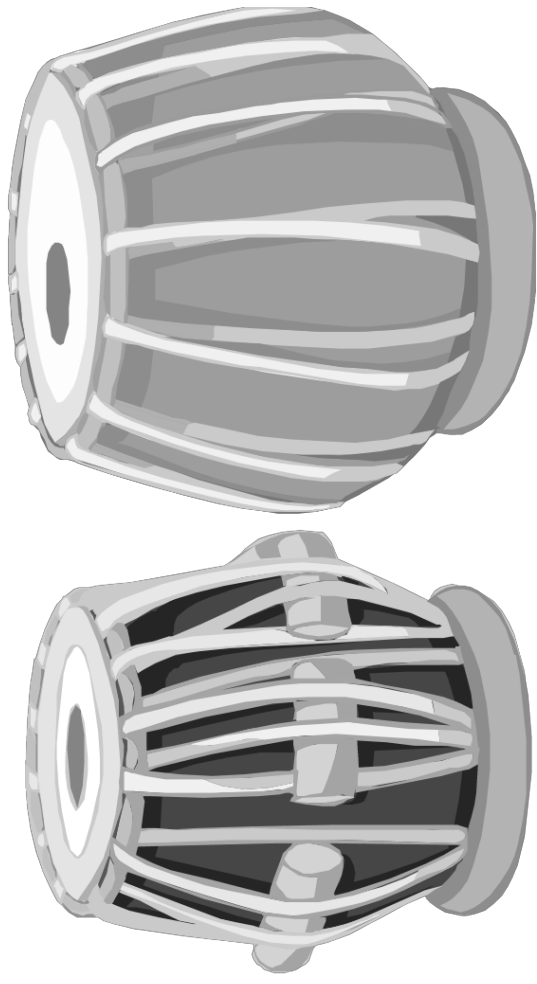
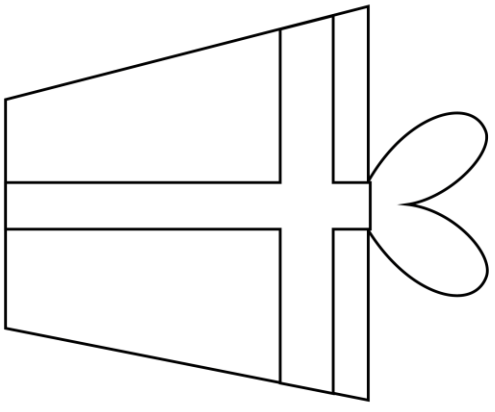

On January 19, Timkat begins. Children march in a parade and play instruments.

Christmas in Ethiopia is called Ganna. They celebrate on January 7.

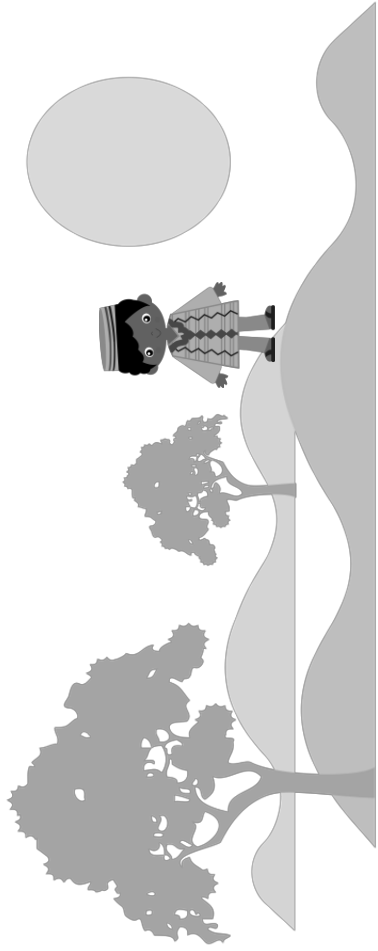

Christmas in Ethiopia



's Book

# Ethiopia

NAME \_\_\_\_\_

FEDERAL DEMOCRATIC REPUBLIC OF ETHIOPIA



Ethiopia celebrates Christmas, which they call Ganna, on January 7. During Ganna, boys like to play a game that is also called ganna. It is a lot like hockey and is played with a curved stick. Instead of a hockey putt, it is played with a round wooden ball.

On January 19, Timkat begins and lasts for three days. Children wear crowns and robes of the church youth groups they belong to while they walk to church services in a parade. In the parade, they play musical instruments.

During Ganna and Timkat, presents are not given or received. Instead, it is a time for church services, eating, and playing games.

# Ethiopia Reading Check

1. On which date is Christmas celebrated in Ethiopia?  
A) December 25                      B) January 7                      C) January 19
2. Christmas in Ethiopia is known as \_\_\_\_\_?  
A) Christmas                      B) Timkat                      C) Ganna
3. What do children do while walking in the Timkat parade?  
A) Pass out candy                      B) Wave                      C) Play instruments
4. How many days are there between Ganna and Timkat?  
A) 2                      B) 7                      C) 12
5. Which sport is similar to ganna?  
A) Timkat                      B) Hockey                      C) Golf
6. Which word describes the stick used to play ganna?  
A) hard                      B) curved                      C) metal
7. In what way does hockey differ from ganna?  
\_\_\_\_\_  
\_\_\_\_\_  
\_\_\_\_\_  
\_\_\_\_\_
8. What was this article mainly about?  
\_\_\_\_\_  
\_\_\_\_\_
9. Which clothing item do children NOT wear during the Timkat parade?  
A) Coat                      B) Crown                      C) Robe
10. Instead of giving or receiving gifts during Ganna and Timkat, what do Ethiopians do?  
\_\_\_\_\_  
\_\_\_\_\_  
\_\_\_\_\_  
\_\_\_\_\_

# Ethiopia

NAME \_\_\_\_\_

## FEDERAL DEMOCRATIC REPUBLIC OF ETHIOPIA



Ethiopia celebrates Christmas, which they call Ganna, on January 7. On the day before Christmas, many Ethiopians fast, or eat nothing. During Ganna, boys like to play a game that is also called ganna. It is a lot like hockey and is played with a curved stick. Instead of a hockey putt, it is played with a round wooden ball.

Twelve days later, on January 19, Timkat begins and lasts for three days.

Timkat celebrates the baptism of Jesus. Children wear crowns and robes of the church youth groups they belong to while they walk to church services in a parade. In the parade, they play musical instruments. During Ganna and Timkat, presents are not given or received. Instead, it is a time for church services, eating, and playing games.

A traditional Christmas dinner in Ethiopia include wat, which is a thick stew containing meat, vegetables and eggs. Wat is served on inera, a large flat piece of bread. Usually, pieces of inera are broken off to use as a spoon. The user will use the inera to scoop up the wat.

Christmas in Ethiopia is most certainly a time for church and family.

# Ethiopia Reading Check

- On which date is Christmas celebrated in Ethiopia?  
A) December 25                      B) January 7                      C) January 19
- Christmas in Ethiopia is known as \_\_\_\_\_?  
A) Christmas                      B) Timkat                      C) Ganna
- What audience do you think the author is writing to?  
\_\_\_\_\_  
\_\_\_\_\_
- How many days are there between Ganna and Timkat?  
A) 2                      B) 7                      C) 12
- Which sport is similar to ganna?  
A) Timkat                      B) Hockey                      C) Golf
- What Ethiopian food item is used to scoop?  
A) Wat                      B) Injera                      C) Spoon
- Compare and contrast hockey and ganna.  
\_\_\_\_\_  
\_\_\_\_\_  
\_\_\_\_\_
- What is the main idea in this article?  
\_\_\_\_\_  
\_\_\_\_\_
- What is the meaning of the word fast in this article?  
A) quick                      B) not eat                      C) run
- What text feature does the author include in this article? How can the reader use it?  
\_\_\_\_\_  
\_\_\_\_\_  
\_\_\_\_\_



Welcome To

# Ethiopia



Teanstellen

means "Hello" pronounced

teen-astell-an

# france



## Shoe Craft

**Purpose:** French children place their shoes by the fireplace on Christmas Eve in hopes that Pere Noel (Santa Claus) will leave them toys and treats. Pere Noel is tall and thin, and he wears a red coat with fur trim.

### Materials:

- Copy of Shoe, Candy Cane, and Lollipop (Cardstock works best, especially for shoe.)
  - Small Piece of Tissue Paper
- Art Supplies – Markers, Crayons, Glue, Glitter, etc.
  - Scissors
- Optional: Saran Wrap for Lollipops

### Procedures:

1. Give each child a copy of a shoe, candy cane, and lollipop.
2. Have students decorate with markers and art supplies. For an added touch, wrap the lollipop in a small piece of saran wrap and secure with tape.
3. To complete, place a small piece of tissue paper and the candy cane and lollipop behind the opening of the shoe and secure with tape or glue.
4. For an added touch, you could create a fireplace bulletin board and have students remove their shoes when arriving in France. An assistant could sneak away to place a small treat in students shoes while they are working on their shoe craft. Later you could place the shoe crafts below the fireplace bulletin board.

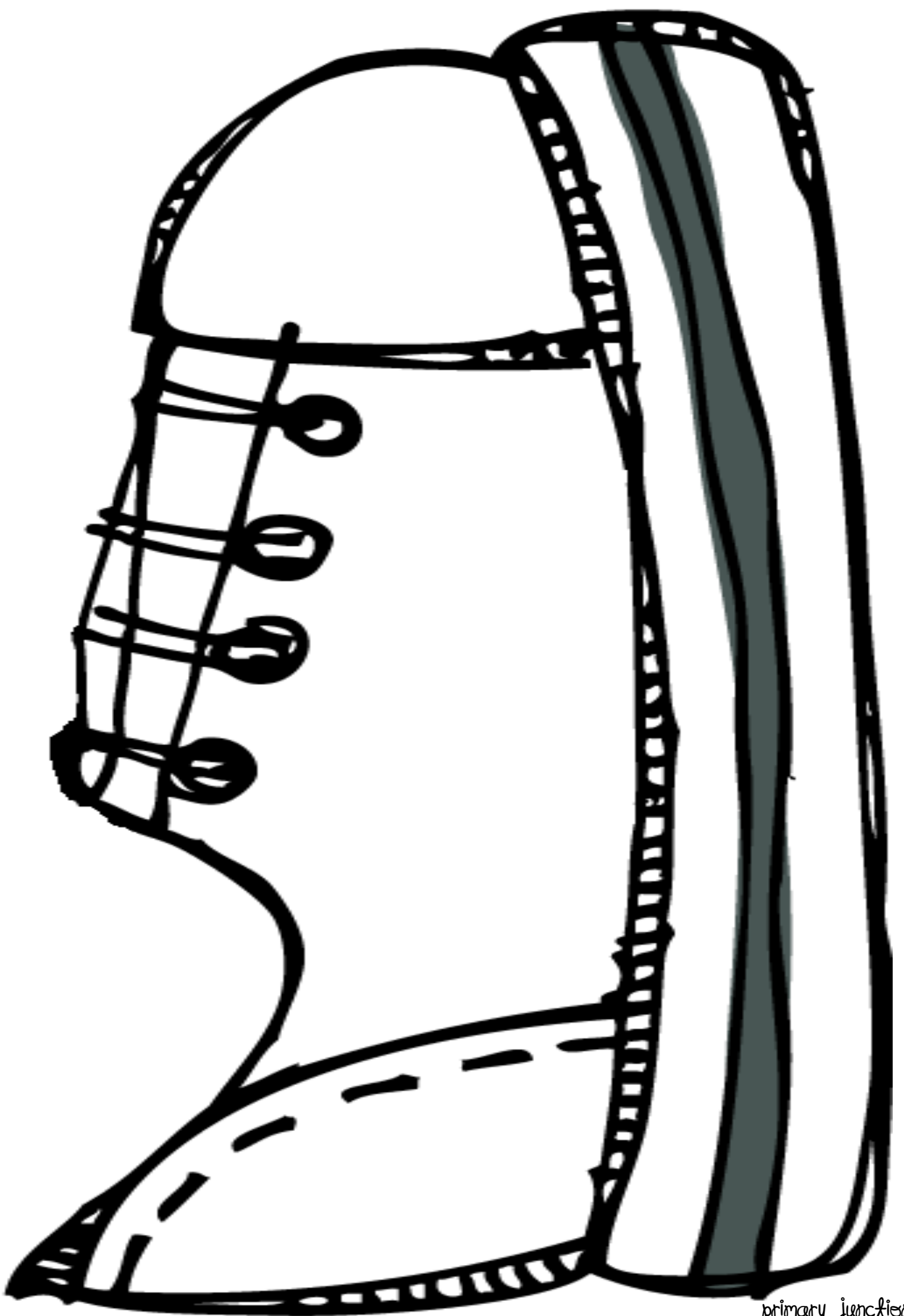

primary junction

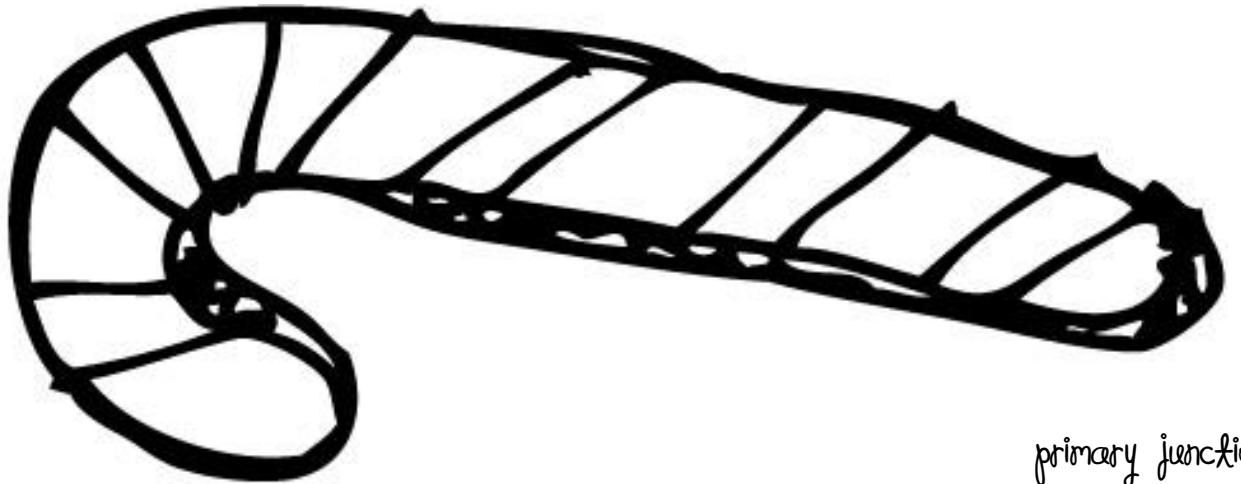
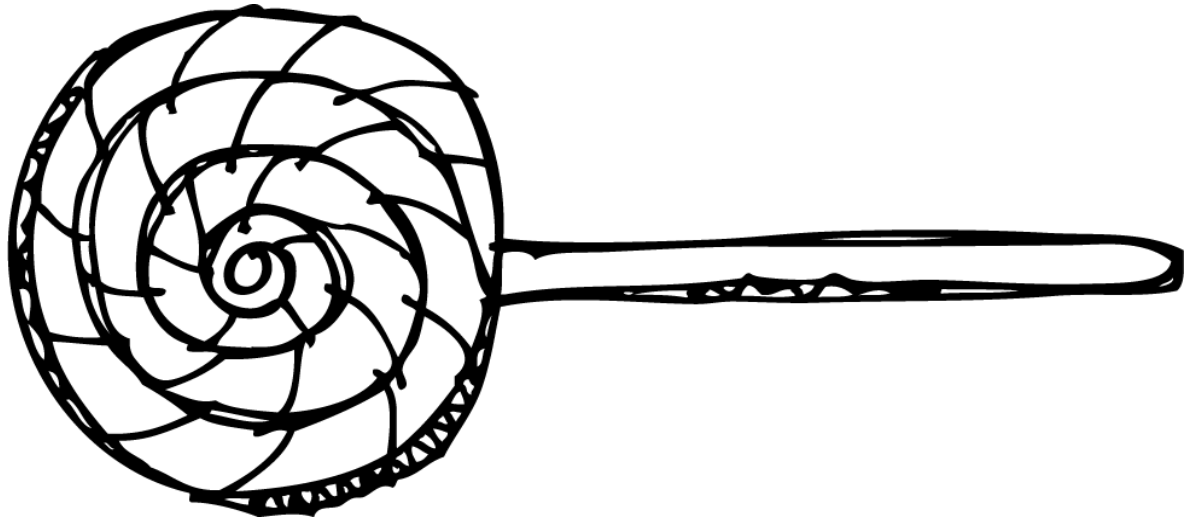
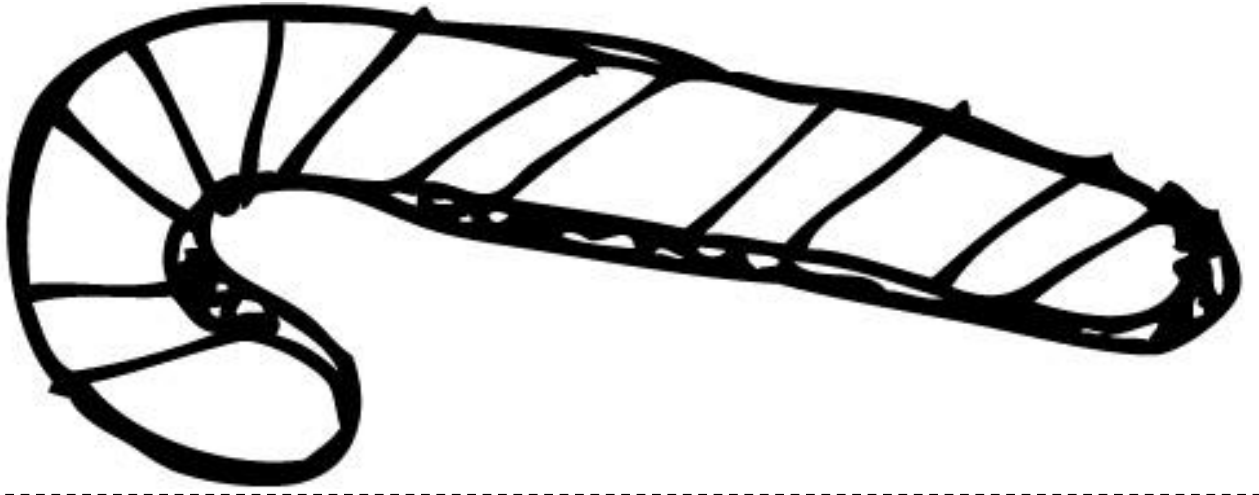
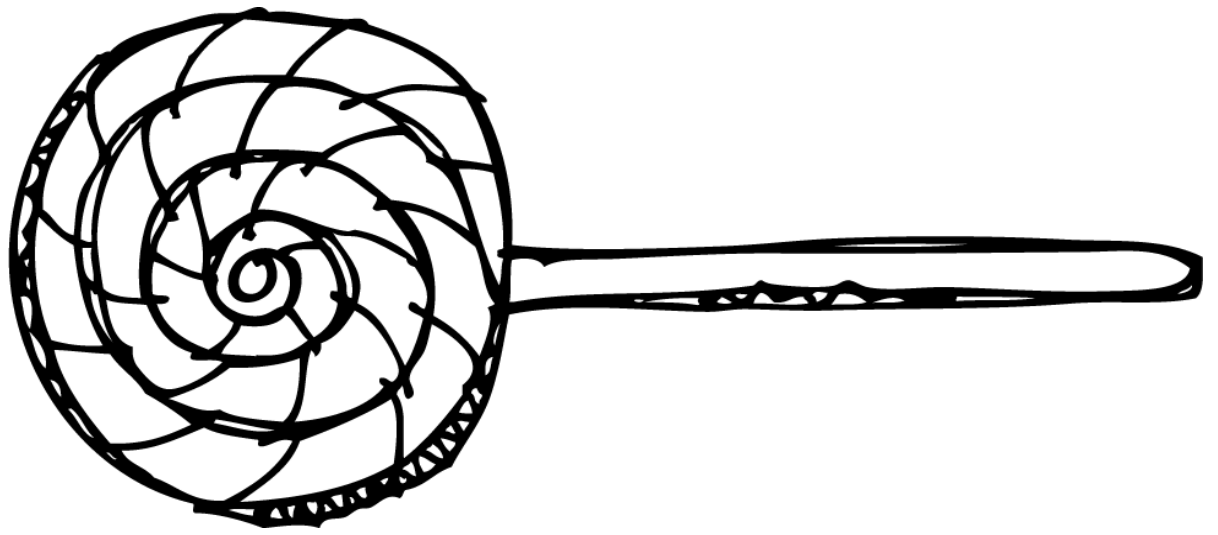

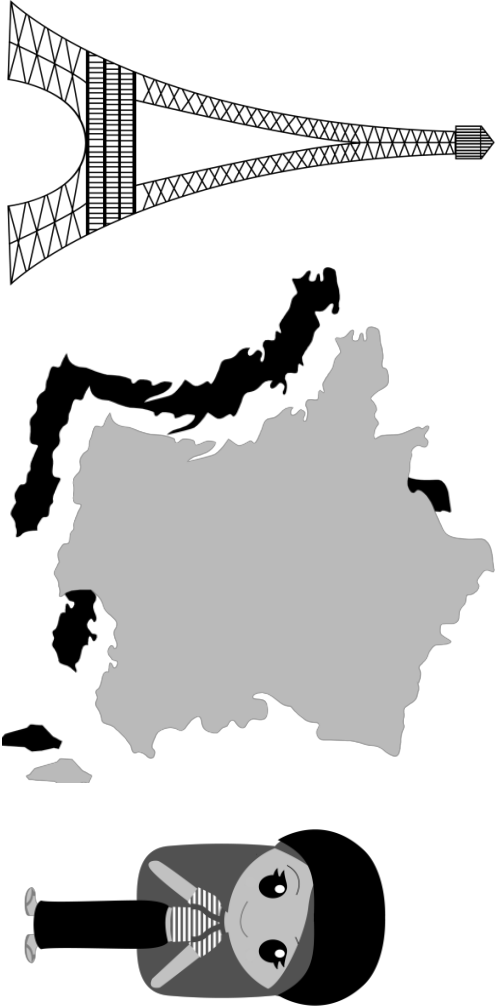

## Christmas in France

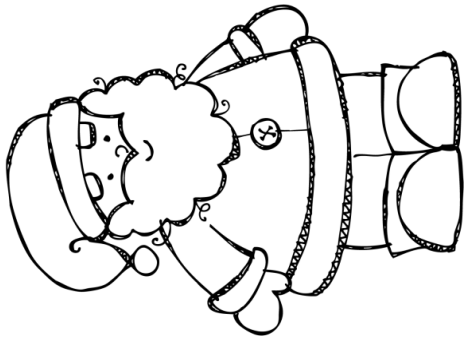

Santa Claus/Father Christmas is known in France as Père Noël. He travels with Le Père Fouettard. Le Père Fouettard looks after naughty children.

The French burn yule logs made of Cherry Wood to make their homes smell good.

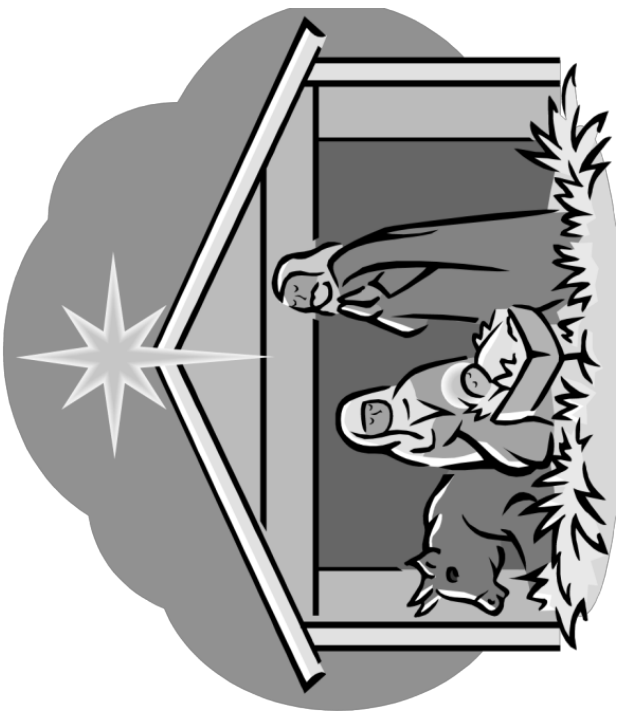

The nativity scene is used as a decoration in many French homes.

# France

NAME \_\_\_\_\_

## FRENCH REPUBLIC

Where in the world  
is France?

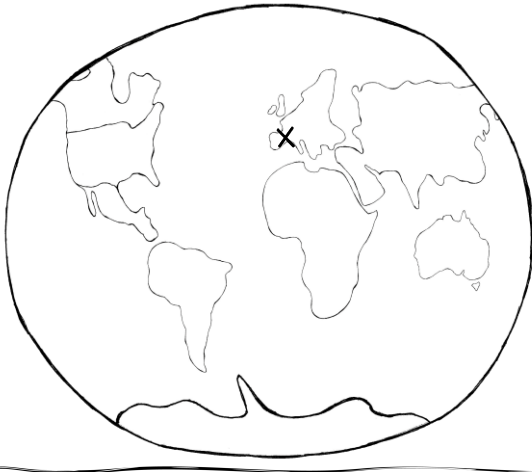

Did you know that Santa Claus (Father Christmas) is known in France as Père Noël? He travels with Le Père Fouettard. Père Noël gives gifts to well-behaved children, while Le Père Fouettard punishes naughty children. Le Père Fouettard dresses in all black.

The nativity scene is used as a decoration in many French homes. The French nativity scene is unique for two reasons: 1) the figures are made out of clay, not wood and 2) it includes figures such as a butcher, a baker, a policeman and a priest.

The French often burn yule logs made of Cherry Wood to make their homes smell nice. On Christmas Eve, the yule log is brought into the home and sprinkled with red wine. This helps it smell very good as it is burning.

As the French say, "Joyeux Noël" (pronounced joy-yu noh-well) (Merry Christmas)!

# France Reading Check

- Santa Claus/Father Christmas is known as \_\_\_\_\_ in France?  
A) Father Christmas                      B) Père Noël                      C) Le Père Fouettard
- Le Père Fouettard dresses in what color?  
A) Red    B) Green    C) Black
- What is used as a decoration in many French homes?  
A) Wreath    B) Nativity Scene    C) Mistletoe
- Why do some French homes burn yule logs at Christmas?  
A) To keep their home warm  
B) To make their home smell nice  
C) To send letters to Père Noël
- What reading genre is this article an example of?  
A) Fiction    B) Non-Fiction    C) Biography
- Which paragraph informs the reader how to say 'Merry Christmas' in French?  
A) Two    B) Three    C) Four
- What did you learn from reading this article?  
\_\_\_\_\_  
\_\_\_\_\_  
\_\_\_\_\_
- Which text feature below would best add to this article?  
A) Graph    B) Photo    C) Diagram
- What is Le Père Fouettard's job?  
A) Give presents                      B) Guide Santa's Sleigh                      C) Punish naughty children
- What is special about the French Nativity scene?  
\_\_\_\_\_  
\_\_\_\_\_  
\_\_\_\_\_

# France

NAME \_\_\_\_\_

## FRENCH REPUBLIC

Where in the world  
is France?

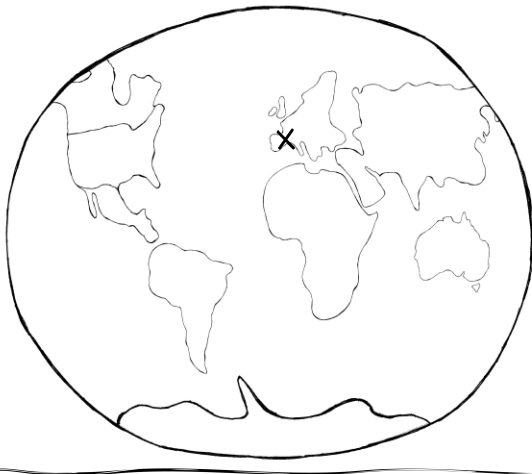

Did you know that Santa Claus (Father Christmas) is known in France as Père Noël? In eastern France, Père Noël travels with Le Père Fouettard. Père Noël gives gifts to well-behaved children, while Le Père Fouettard disciplines the naughty children. Le Père Fouettard dresses in all black.

The nativity scene is used as a decoration in many French homes. The French nativity scene is unique for two reasons: 1) the figures are made out of clay, not wood and 2) it includes figures such as a butcher, a baker, a policeman and a priest.

The French often burn yule logs made of Cherry Wood to make their homes smell nice. On Christmas Eve, the yule log is brought into the home and sprinkled with red wine. This helps it smell nice as it is burning.

The French Christmas meal is called Réveillon. On the table are dishes such as roast turkey or goose, oysters, lobster, and cheeses. For dessert, a chocolate sponge cake log called a bûche de Noël is served. In some parts of France, thirteen desserts, made from different types of fruit, nuts, and pastries, are served!

As the French say, "Joyeux Noël" (pronounced joy-yu noh -well) (Merry Christmas)!



# France Reading Check

- Santa Claus/Father Christmas is known as \_\_\_\_\_ in France?  
A) Father Christmas                      B) Père Noël                      C) Le Père Fouettard
- Le Père Fouettard dresses in what color?  
A) Red    B) Green    C) Black
- What can the reader learn from the text feature included with this article?  
\_\_\_\_\_  
\_\_\_\_\_  
\_\_\_\_\_
- Which child below might receive a visit from Le Père Fouettard?  
A) Suzy who shares her toys.  
B) Billy who doesn't follow directions from his parents and teachers.  
C) Jack who uses manners and is respectful to adults and his classmates.
- What reading genre is this article an example of?  
A) Fiction    B) Non-Fiction    C) Biography
- Which paragraph informs the reader how to say 'Merry Christmas' in French?  
A) Three    B) Four    C) Five
- How did you use your prior knowledge to help you better understand this article?  
\_\_\_\_\_  
\_\_\_\_\_  
\_\_\_\_\_  
\_\_\_\_\_
- Which text feature below would best add to this article?  
A) Graph    B) Photo    C) Diagram
- What is the name of the French chocolate sponge cake log?  
A) Bûche de Noël    B) Yule Log    C) Le Père Fouettard
- What is special about the French Nativity scene?  
\_\_\_\_\_  
\_\_\_\_\_  
\_\_\_\_\_  
\_\_\_\_\_

Welcome To

France

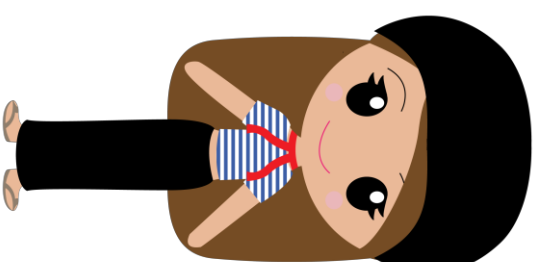
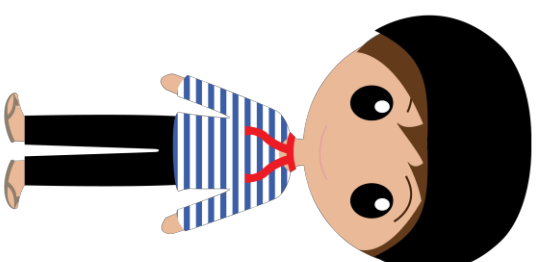
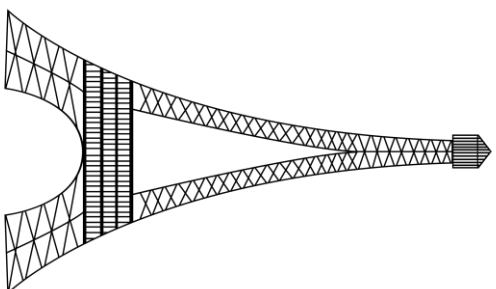
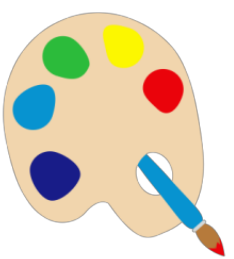
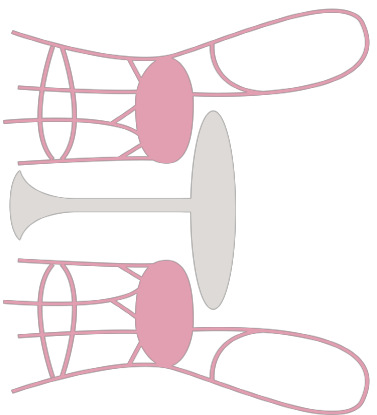

Bonjour

means "Hello"  
Pronounced Bohn-joor

# germany



**Christmas Tree Puppet**

**Purpose:** Christmas Trees are very important in Germany. They were actually first used in Germany during the Middle Ages. Traditionally, the tree is brought into the house on Christmas Eve and after it is decorated, families will read the Bible and sing Christmas songs.

### **Materials:**

- Paper Bag
- Copy of Christmas Tree and O Christmas Tree Lyrics
- Glue stick
- Crayons

### **Procedures:**

1. Give students a copy of the Christmas Tree and O Christmas Tree Lyrics.
2. Students will color the Christmas Tree and then cut it and the song lyrics out.
3. Students will glue the Christmas Tree on the flap side and the lyrics on the flat side. The top of the Christmas tree will go on the flap, while the bottom half will go just barely underneath the flap.
4. Have students read the song lyrics silently and with a partner. Then, play the song for the class before singing it together with the puppets!

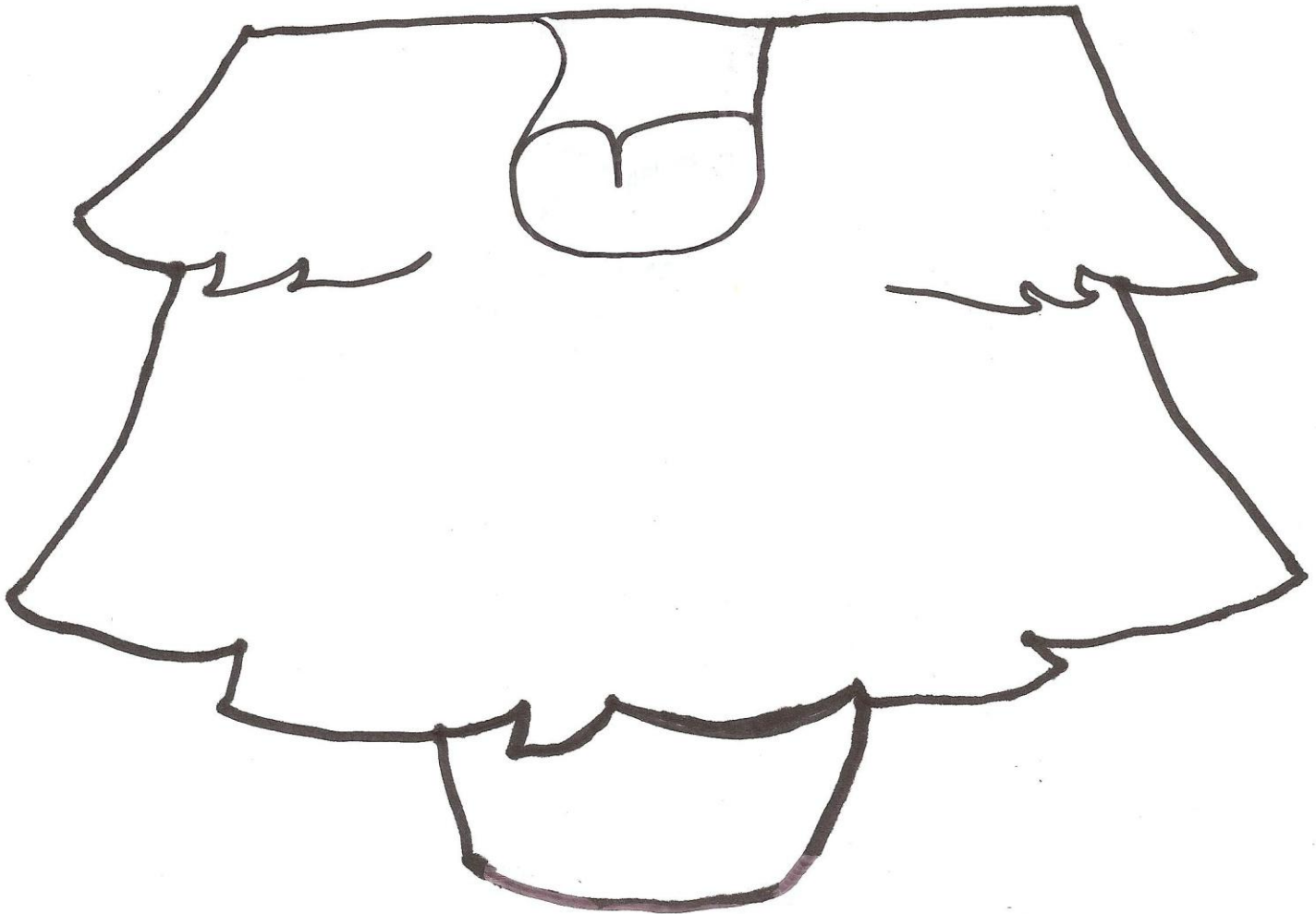

# Oh Christmas Tree

Oh Christmas tree,

Oh Christmas tree!

Your leaves are so unchanging.

Oh Christmas tree,

Oh Christmas tree!

Your leaves are so unchanging.

Not only green,

When summer's here,

But also when 'tis cold and  
drear.

Oh Christmas tree,

Oh Christmas tree!

Your leaves are so unchanging.

# Oh Christmas Tree

Oh Christmas tree,

Oh Christmas tree!

Your leaves are so unchanging.

Oh Christmas tree,

Oh Christmas tree!

Your leaves are so unchanging.

Not only green,

When summer's here,

But also when 'tis cold and  
drear.

Oh Christmas tree,

Oh Christmas tree!

Your leaves are so unchanging.

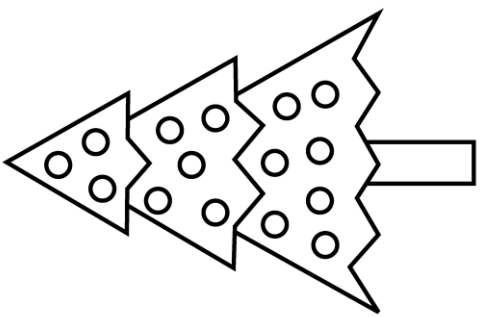

The Christmas tree was first used in Germany. When some Germans moved to other parts of the world, others started using Christmas trees too.

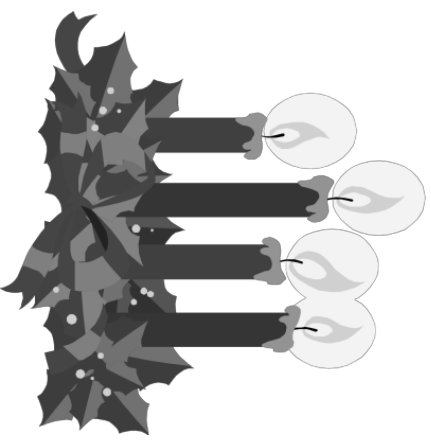

Another tradition is Advent, a time of waiting for Christmas. It starts on December 1 and counts the days until Christmas. Each day honors a part of the Christmas story.

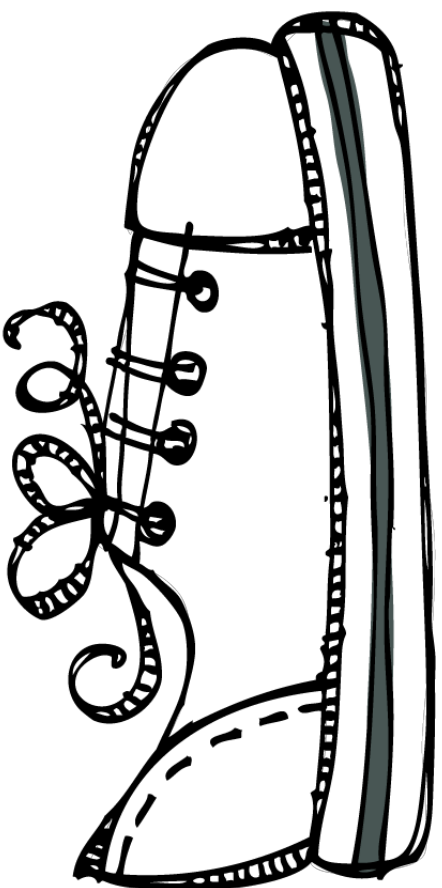

December 6 is St. Nicholas Day. On the night before, children leave a shoe out. St. Nicholas visits at night and leaves treats in the shoe.

## Christmas in Germany

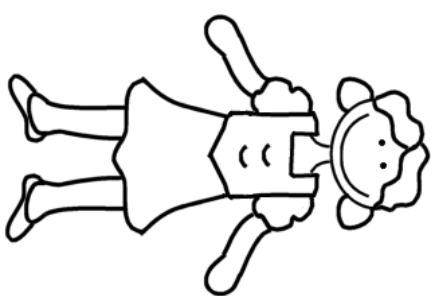
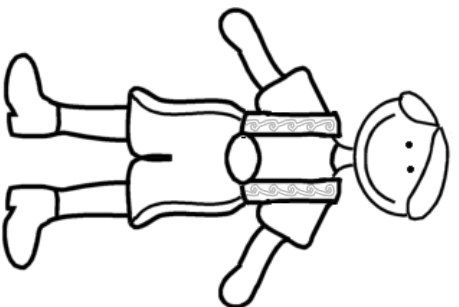

# GERMANY

NAME \_\_\_\_\_

## FEDERAL REPUBLIC OF GERMANY

Where in the world  
is Germany?

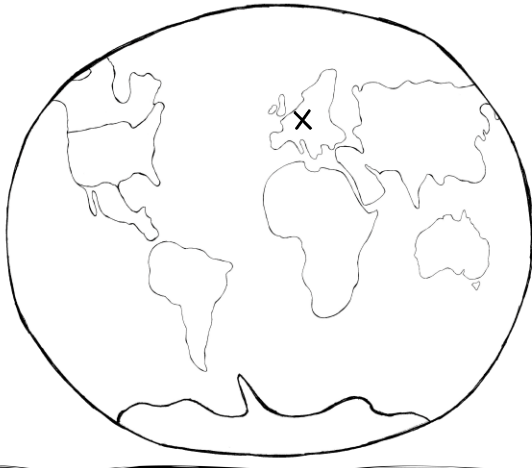

Christmas in Germany is a time for family, friends, and traditions.

The Christmas season starts on December 6. That is St. Nicholas Day. On December 5, children will leave a shoe near a fireplace or door. St. Nicholas visits that night and leaves a small toy or piece of candy in their shoe. Christkind, who has blonde hair and wings, then visits on Christmas Eve to leave gifts for children. Families meet on Christmas day. They might eat Goose and Stollen, a fruited bread.

Did you know the Christmas tree was first used in Germany? When some Germans moved to other parts of the world, others began to use Christmas trees too.

Another tradition in Germany is Advent. Advent is a time of waiting for Christmas. Many German homes have an Advent Calendar. It starts on December 1 and counts the days until Christmas. The calendar has 24 spots that hold a small gift that is about part of the Christmas story. During this time, Germany also has Christmas Markets. They are in the town square. You can buy food and Christmas things there.

Germany has a lot of Christmas traditions! What traditions do you follow?

# GERMANY READING CHECK

1. Who leaves a small toy or piece of candy in children's shoes?  
A) Father Christmas                      B) St. Nicholas                      C) The Christkind

2. What is Stollen?  
A) A Calendar                      B) An Angel                      C) Fruited Bread

3. Explain how the Christmas tree spread from Germany to other countries.

---

---

---

---

4. What is Advent?  
A) A Christmas Market  
B) A time of waiting for Christmas  
C) A month

5. When does Advent begin?  
A) December 6                      B) December 1                      C) December 24

6. Which of the following items might you **NOT** find in an Advent Calendar?  
A) Large toy                      B) Chocolate                      C) Part of the Christmas Story

7. What might you see at a Christmas Market?

---

---

---

---

8. Which paragraph in this article includes information about the Christkind?  
A) 1                      B) 2                      C) 3

9. What is the main idea of this article?  
A) Advent                      B) Christmas Trees                      C) Christmas in Germany

10. Name and describe a tradition you follow.

---

---

---

---



# GERMANY

NAME \_\_\_\_\_

## FEDERAL REPUBLIC OF GERMANY

Where in the world  
is Germany?

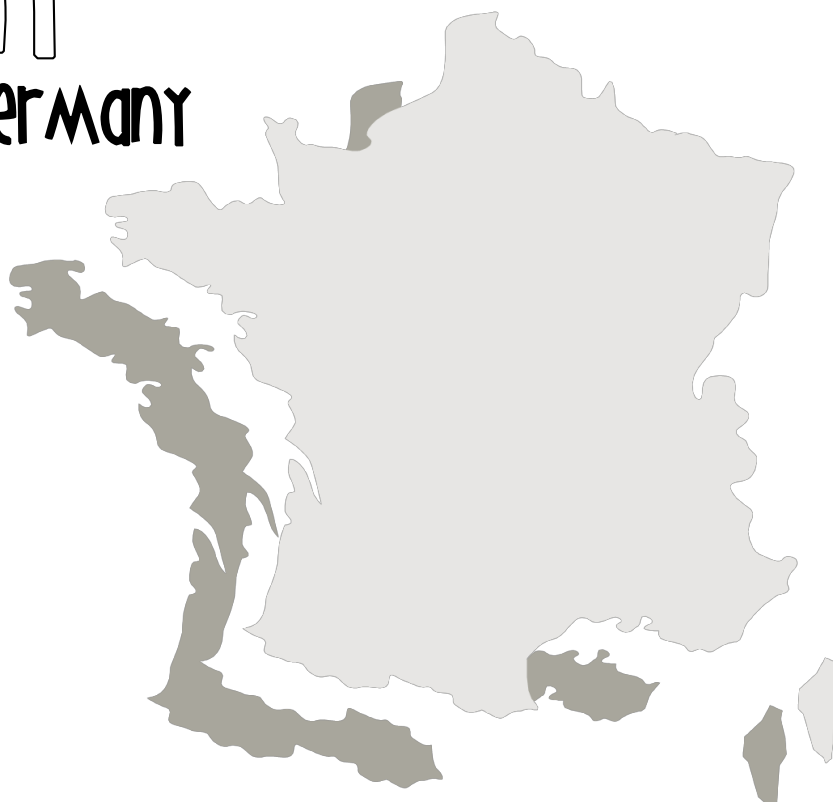
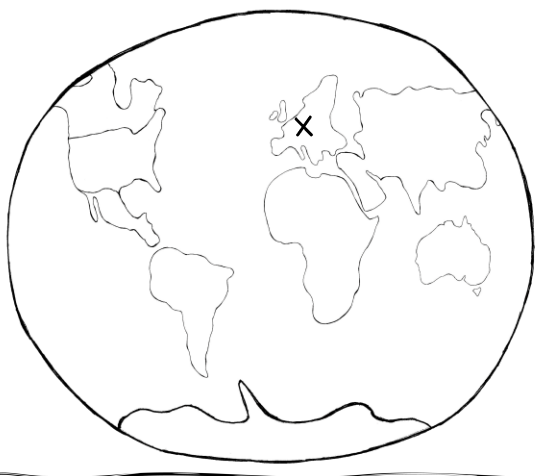

Christmas or Weihnachten is most certainly a magical time in Germany. It is a time for family, friends, and traditions.

Traditionally, the German Christmas celebration begins on December 6, which is St. Nicholas Day. On the night before, children will leave a shoe near a fireplace or bedroom door. During the night, St. Nicholas will visit and leave small gifts such as candy or chocolate in their shoes.

Christkind visits homes on Christmas Eve to leave gifts for children. The Christkind is said to have blonde hair and wings. Christmas Eve is also the day that most German families exchange gifts. On Christmas, families gather for a Christmas meal. The main dish usually includes Carp or Goose and Stollen, a fruited yeast bread.

The Christmas tree first originated in Germany. They were first used in the Middle Ages. Through the years as Germans moved to other parts of the world, they took their custom of Christmas trees with them, and it caught on.

Another tradition that is very important in Germany is Advent. Advent is a time of waiting for Christmas and celebrating the Christmas story. You might have seen an Advent calendar before. Many German homes have them. An Advent calendar begins on December 1 and counts the days until Christmas. There are many different types of Advent calendars, but they each have 24 boxes, bags, or windows that hold a small gift and often includes a part of the Christmas story. During Advent, Christmas Markets are also popular. These markets usually take place in the town square and sell food and Christmas items.

Christmas in Germany is full of traditions! What traditions do you follow?

# GERMANY Reading Check

1. Who leaves a small toy or piece of candy in children's shoes?  
A) Father Christmas                      B) St. Nicholas                      C) The Christkind

2. What is Stollen?  
A) A Calendar                      B) An Angel                      C) Fruited Bread

3. Explain how the Christmas tree spread from Germany to other countries.

---

---

---

---

4. Who might **BEST** benefit from reading this article?  
A) A reader who wants to learn about the history of Christmas  
B) A reader who wants to compare Christmas traditions throughout the world  
C) A reader who wants to learn about Germany

5. When does Advent begin?  
A) December 6                      B) December 1                      C) December 24

6. What information in this article would you **NOT** include in a text summary?

---

---

---

7. What might you see at a Christmas Market?

---

---

---

---

8. As a reader, what text-to-text, text-to-self, and/or text-to-world connections did you make with this article?

---

---

---

---

9. What is the main idea of this article?  
A) Advent                      B) Christmas Trees                      C) Christmas in Germany

10. Describe a tradition you follow.

---

---

---

---

Welcome to

# Germany

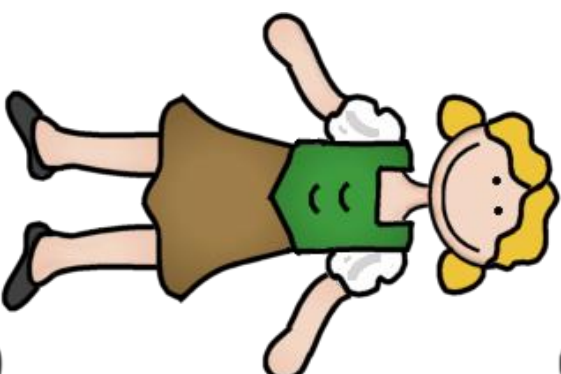
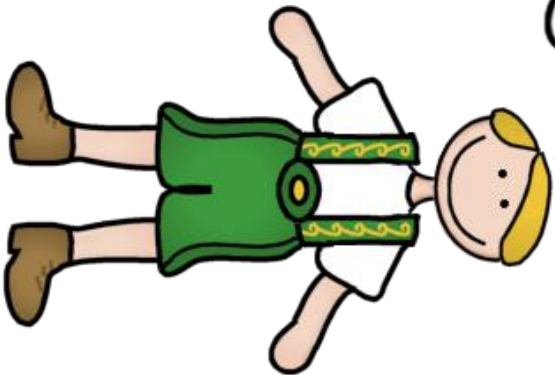

Hallo

means "Hallo"  
pronounced hall-o

# holland



**Wooden Shoes**

**Purpose:** Children leave clogs out on December 5th to be filled with presents. They believe that if they leave hay and carrots in their shoes for Sinterklaas' horse, he will also leave them some sweets. Children are told that good children will get presents from Sinterklaas, but bad children will get chased by Zwarte Piet, a companion of Sinterklaas, with a stick!

## **Materials:**

- Construction Paper (Yellow and Other Colors)
- Copy of Shoe Template
- Scissors
- Glue
- Yarn
- Tape

## **Procedures:**

1. Give each child a copy of the shoe template. Students should trace shoe on yellow construction paper then flip the shoe and trace again to complete pair. Then trace the smaller template on another piece of construction paper.
2. Students will place the smaller template in front of the "hump" at the top of the wooden shoe and glue.
3. Have students create a small design to fit on the smaller construction paper and glue.
4. Tape a piece of yarn to the back of the shoes to connect.

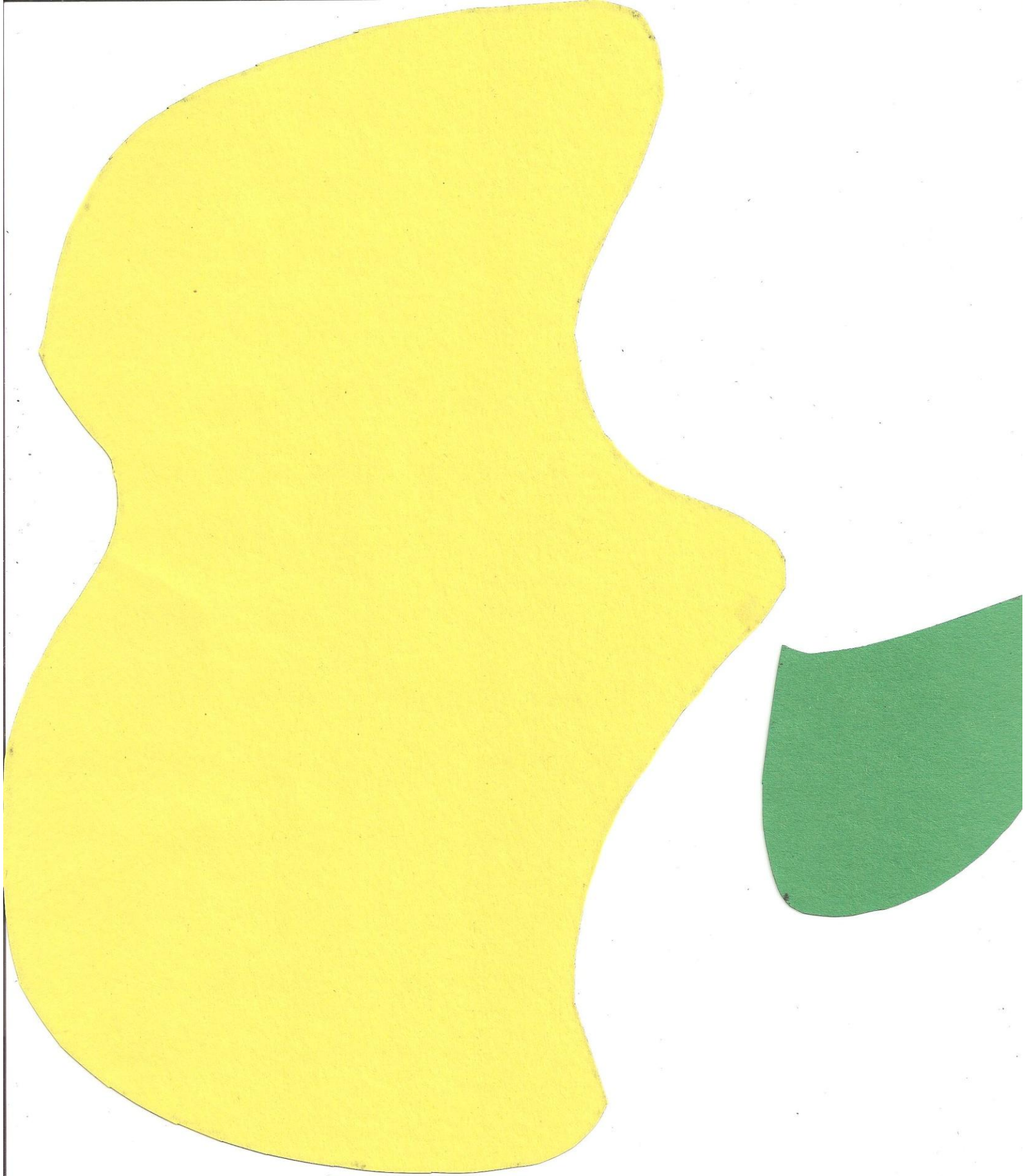

# WOODEN SHOES TEMPLATE

*primary junction*



# Christmas in Holland

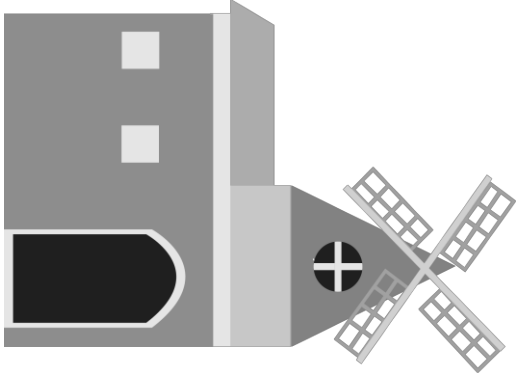

Christmas Day in Holland is a quiet day.  
Many families go to church and then  
share a meal.

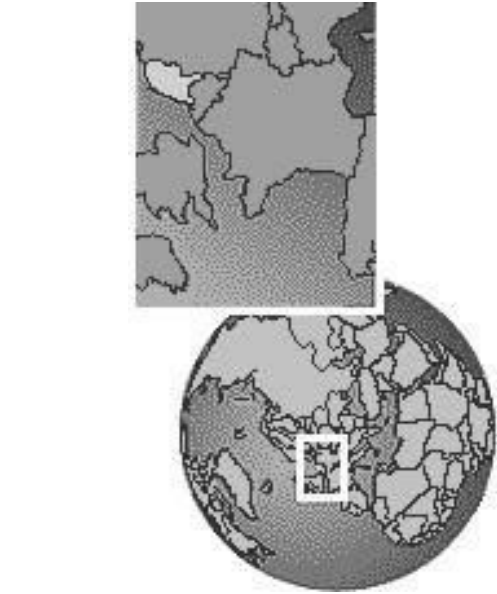
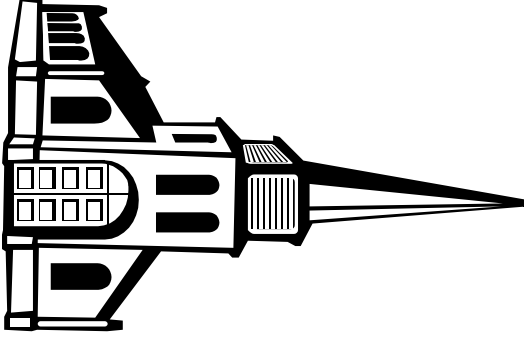

Holland is not a country. It is part of the  
Netherlands, which is a country.

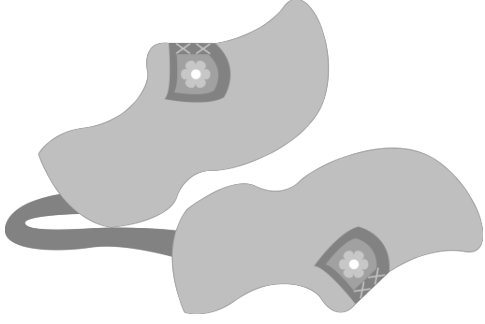
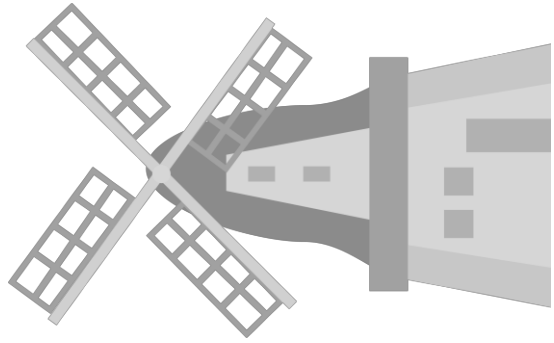

Sinterklaas (St. Nicholas) visits on  
December 5. At night, children leave  
clogs or shoes out in hopes of getting  
gifts.

# HOLLAND

NAME \_\_\_\_\_

where in the world  
is Holland?

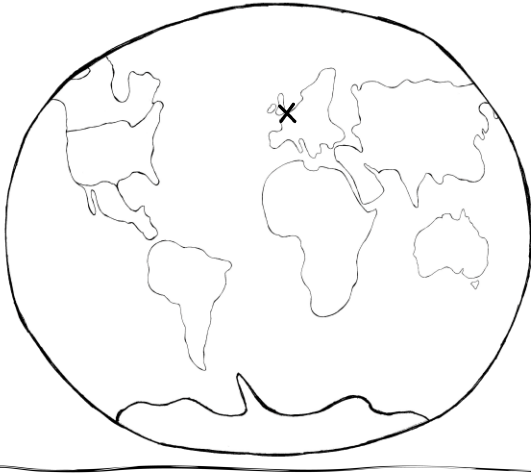

Holland is not a country. It is part of the Netherlands, which is a country. The Netherlands is sometimes called Holland though. Some people who live in The Netherlands but not Holland do not like it.

Now, let's talk about Christmas in Holland! The season starts on December 5<sup>th</sup> when Sinterklaas (St. Nicholas) visits. At night, children leave clogs or shoes out in hopes of getting gifts. Some children may also leave hay and carrots for Sinterklaas's horse. Parties may also be held on this night. There, children follow clues to find gifts left for them. Many types of sweets are at the parties. One sweet is a letter blanket, which is a biscuit made in the shape of a letter.

December 6 is St. Nicholas Day. In the morning, Sinterklaas goes to a city in the Netherlands. Every year he goes to a different city so more children can see him. With him is his servant Zwarte Piet (Black Peter). Good children get presents from Sinterklaas, while naughty children get chased by Zwarte Piet! Sinterklaas then rides in a parade.

Christmas Day in Holland is a quiet day. Many families go to church and then share a meal. Children usually do not get gifts because they already got gifts earlier from Sinterklaas.

What Holland tradition do you want to learn more about?





# HOLLAND

NAME \_\_\_\_\_

Where in the world  
is Holland?

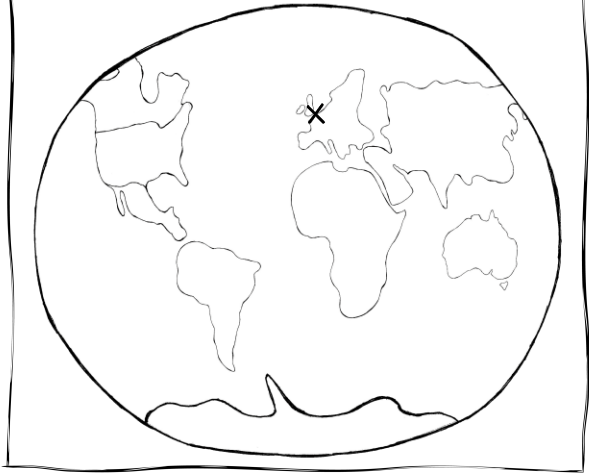

Holland is not actually a country. Instead, it is a region in the western part of The Netherlands, which is a country. The Netherlands is sometimes called Holland though, even though Holland is only part of the country. Some people who live there are fine with this but many others who do not live in the direct Holland area do not like it. Today, the region of Holland is split into North Holland and South Holland. Major cities in this area include Amsterdam and Rotterdam. Now that you know a little bit about Holland, let's talk about Christmas in Holland!

The Christmas season begins in Holland on December 5<sup>th</sup> when Sinterklaas (St. Nicholas) visits. On this night, children leave clogs or shoes out in hopes of receiving small gifts and treats. Some children may also leave hay and carrots for Sinterklaas's horse. Some parties are also held on this night. Children often follow clues to find presents left for them. A lot of sweets are included at the parties as well. One popular sweet is a letter blanket, which is a biscuit made in the letter shape of attendees' first names. The following day, December 6, is St. Nicholas Day. During the early morning hours, Sinterklaas travels to a city in The Netherlands. Every year he travels to a different city so as many children as possible can see him. With him is his servant Zwarte Piet (Black Peter). He keeps track of everything each child has done in the past year. Well-behaved children receive presents from Sinterklaas, while poorly-behaved children might get chased by Zwarte Piet who carries a stick! After church bells ring to signal their arrival, Sinterklaas parades through town on a white horse.

Christmas Day in Holland is much quieter with most of the focus on church services and family get-togethers. Children usually do not receive any gifts on this day as they have already received their gifts from Sinterklaas on St. Nicholas Day.

What Holland Christmas tradition do you find most interesting?



Welcome To

# Holland

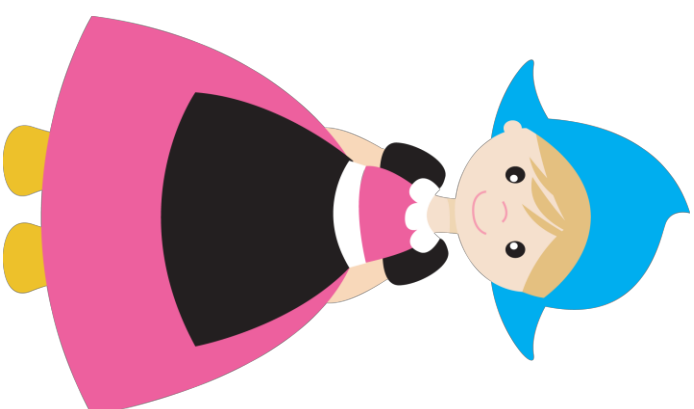
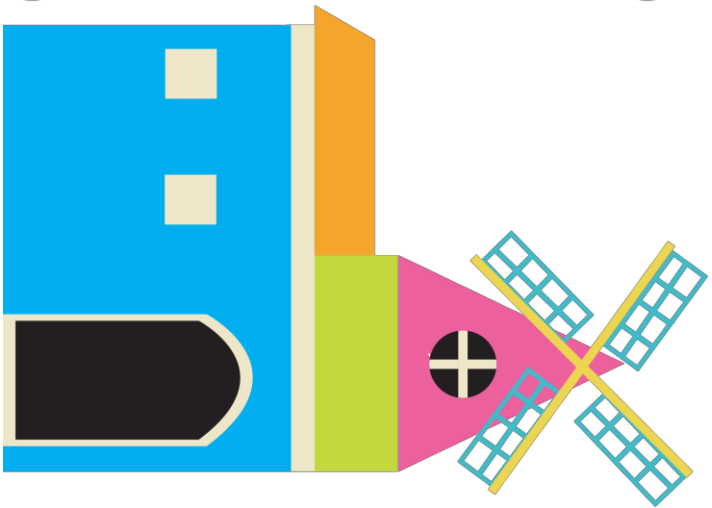

Hallo

means "Hello"  
pronounced hollow

# italy



**La Befana's Broom**

**Purpose:** In Italy children wait until Epiphany on January 6 for their presents. La Befana, a kind witch, delivers the presents on a broomstick. It is said that she was busy and delayed visiting baby Jesus when he was born. She missed the Star and lost her way. She has been flying around ever since, leaving presents at every house with children in case he is there. She flies down chimneys and fills stockings and shoes with nice things for good children and leaves coal for children who misbehave.

#### **Materials:**

- A paper lunch bag
- A paper towel tube
- Scissors
- Rubber Band

#### **Procedures:**

1. Give each child a paper lunch bag with lines (about 1cm wide) drawn from the bottom to about three quarters of the way up.
2. Students cut along the lines.
3. When finished cutting, wrap the top part of the bag around the paper towel tube and secure with a rubber band.
4. Students can then trim the bottom of the bag for a more authentic look if wanted.



Naples, Italy makes a lot of nativity cribs.  
Many homes in Italy have their own set.



Many children sing carols at Christmas.  
Some also wear shepherds sandals and hats  
while playing songs on shepherds pipes.

## Christmas in Italy



On the night of January 5, children place  
stockings by a fireplace in hopes of a visit  
from La Befana. She is an older woman who  
rides on a broomstick. Some say she sweeps  
the floors of homes she visits.

# Italy

NAME \_\_\_\_\_

Where in the world  
is Italy?

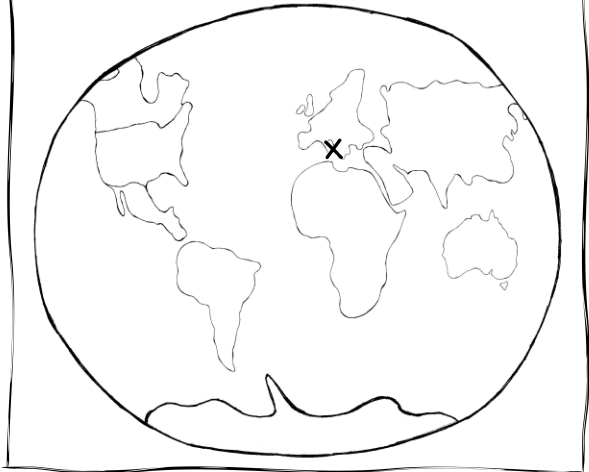

The nativity crib scene is special to Italy. Naples, Italy makes a lot of the cribs. Many homes in Italy have their own Nativity crib. They are placed in homes on December 8, but the figure of baby Jesus is not placed in the crib until the night of December 24.

Many children sing carols at Christmas. Some also wear shepherds sandals and hats while playing songs on shepherds pipes.

In Italy going to Midnight Mass at church on Christmas Eve is special. On this day no food is eaten until Midnight Mass is over. On Christmas Day, families share a meal. They might eat Panettone, an Italian fruit sponge cake.

Babbo Natale (Santa Claus) might bring a few small gifts on Christmas, but most children in Italy do not get gifts until Epiphany, which is on January 6. On the night of January 5, children place stockings by a fireplace in hopes of a visit from La Befana. La Befana is an older woman who rides on a broomstick. Some say she sweeps the floors of homes she visits. While visiting, Le Befana fills stockings with candy and presents. Naughty children might get a lump of coal or dark candy.

Christmas traditions are very special to the people of Italy.

# Italy Reading Check

1. Naples, Italy is known for making \_\_\_\_\_?  
A) Brooms                                      B) Nativity Cribs                                      C) Panettone
2. What special event happens on Christmas Eve?  
A) Midnight Mass                                      B) Epiphany                                      C) La Befana's arrival
3. What text feature could the author add to this article to help the reader better understand it?

---

---

---

---

4. What is Panettone?  
A) Fruit Cake                                      B) Shepherds Pipes                                      C) Song
5. When is Epiphany?  
A) December 24                                      B) January 5                                      C) January 6
6. Which of the gifts below might La Befana leave for a naughty child?  
A) Dark Candy                                      B) Computer                                      C) Doll

7. How does the author describe La Befana?  

---

---

---

---

8. What was this article mostly about?  

---

---

9. Create a new title for this article.  

---

---

10. What did you learn from reading this text that surprised you?  

---

---

---

---

# Italy

NAME \_\_\_\_\_

Where in the world  
is Italy?

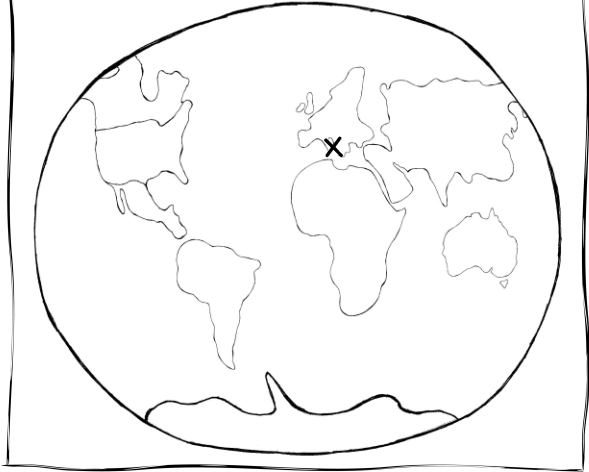

The nativity crib scene holds an important role in Italy's Christmas traditions. Naples, Italy is known for making many of the cribs. They are known as Neapolitan Cribs. Neapolitan Cribs include figures from the crib scene, as well as everyday figures such as politicians, famous people, animals, and more. A lot of homes in Italy have their own Nativity crib. They are usually placed at homes on December 8, but the figure of baby Jesus is not placed in the crib until the night of December 24.

During the Christmas season, it is a popular custom for children to sing carols. Some also wear shepherds sandals and hats while playing songs on shepherds pipes.

In Italy, attending Midnight Mass at church on Christmas Eve is especially important. On this day, no food is eaten until Midnight Mass is over. On Christmas Day, families gather to share a meal. A popular dish ate on this date is Panettone, which is an Italian Christmas Cake that is a fruit sponge cake.

Babbo Natale (Santa Claus) might bring a few small gifts on Christmas, but most children in Italy do not receive gifts until Epiphany, which is on January 6. On the night of January 5, children place stockings by a fireplace in hopes of a visit from La Befana. La Befana is an older woman who rides on a broomstick. Some say she sometimes sweeps the floors of homes she visits. While visiting, Le Befana fills stockings with candy and presents. Naughty children might receive a lump of coal or dark candy. In other parts of Italy, children may receive a visit from the Three Wise Men instead.

Christmas traditions are very important to the people of Italy. Are any Italian Christmas traditions similar to yours?





Welcome To

Italy

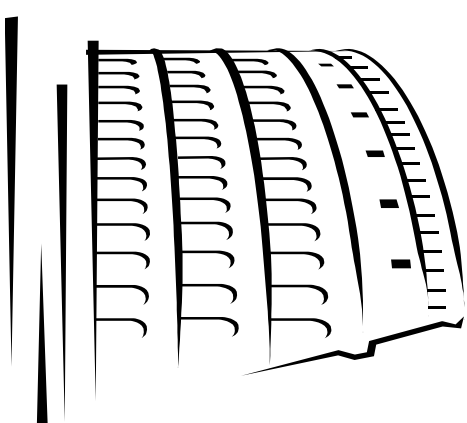
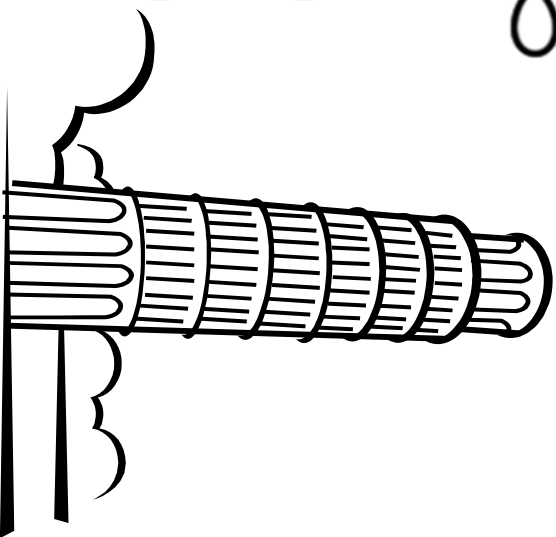

Ciao

means "Hello"  
Pronounced chow

# israel



**Menorah**

**Purpose:** The menorah is a symbol of the Jewish holiday of Chanukah. It is an eight-branched candelabra with a ninth branch for a "helper" candle, called the Shamash. Each of the eight candles represent one of the eight nights of Chanukah. In the second century BCE, a Jewish band of rebels in Judea rescued the Holy Temple in Jerusalem from the Greek pagans who had ransacked it. The group wanted to light the eternal lamp. They found only enough oil to last for one night, but a miracle happened and the oil lasted for eight nights.

### **Materials:**

- Copy of Menorah Base
- Copy of Candles
  - Glue
  - Crayons
- Gold Glitter

### **Procedures:**

1. Give each student a copy of a menorah and nine candles.
2. Students should color the candles and then cut them and the menorah base out.
3. Students should then glue the candles behind the menorah. The middle candle should be placed a little higher than the rest.
4. To complete, place some glue on the candle flames and sprinkle with glitter.

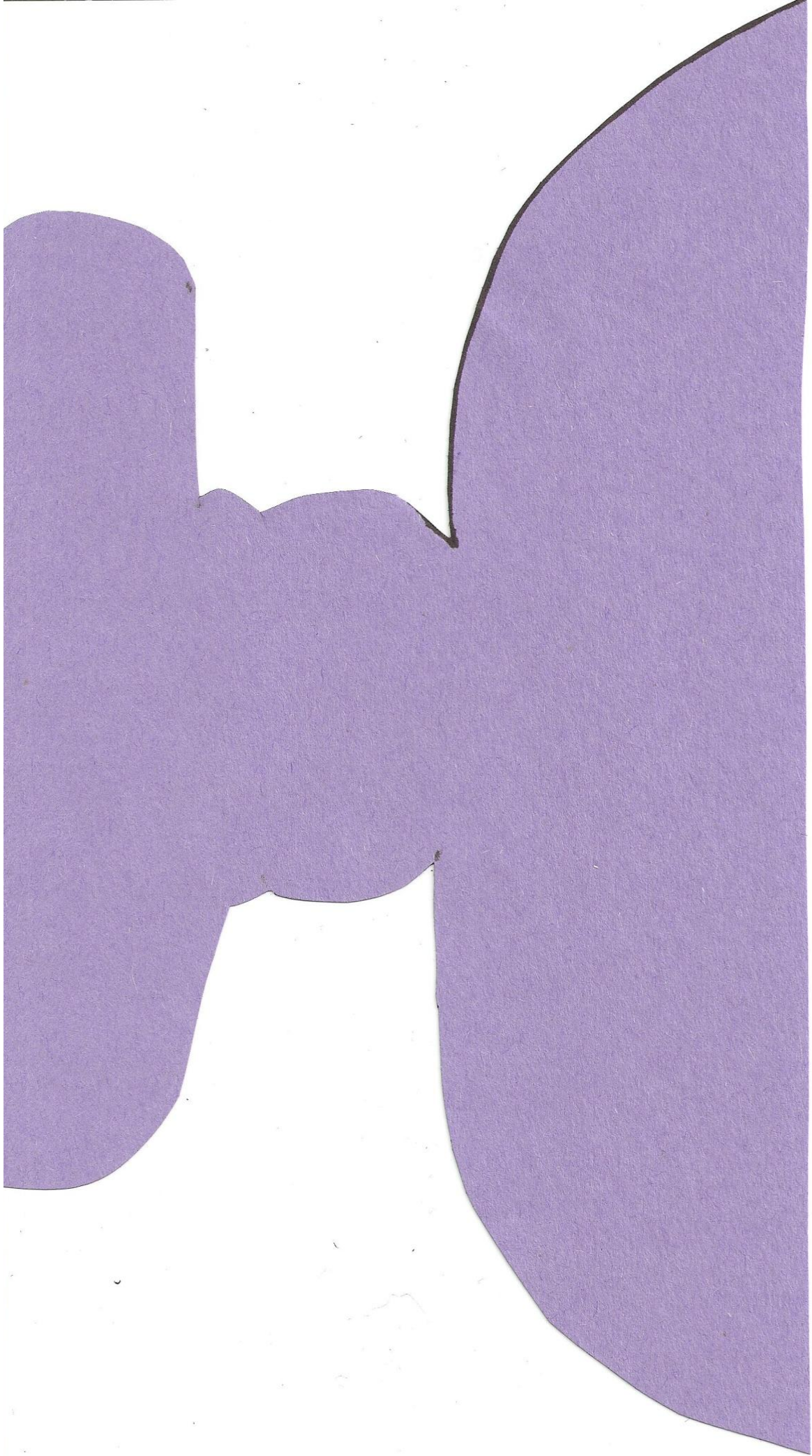

primary junction

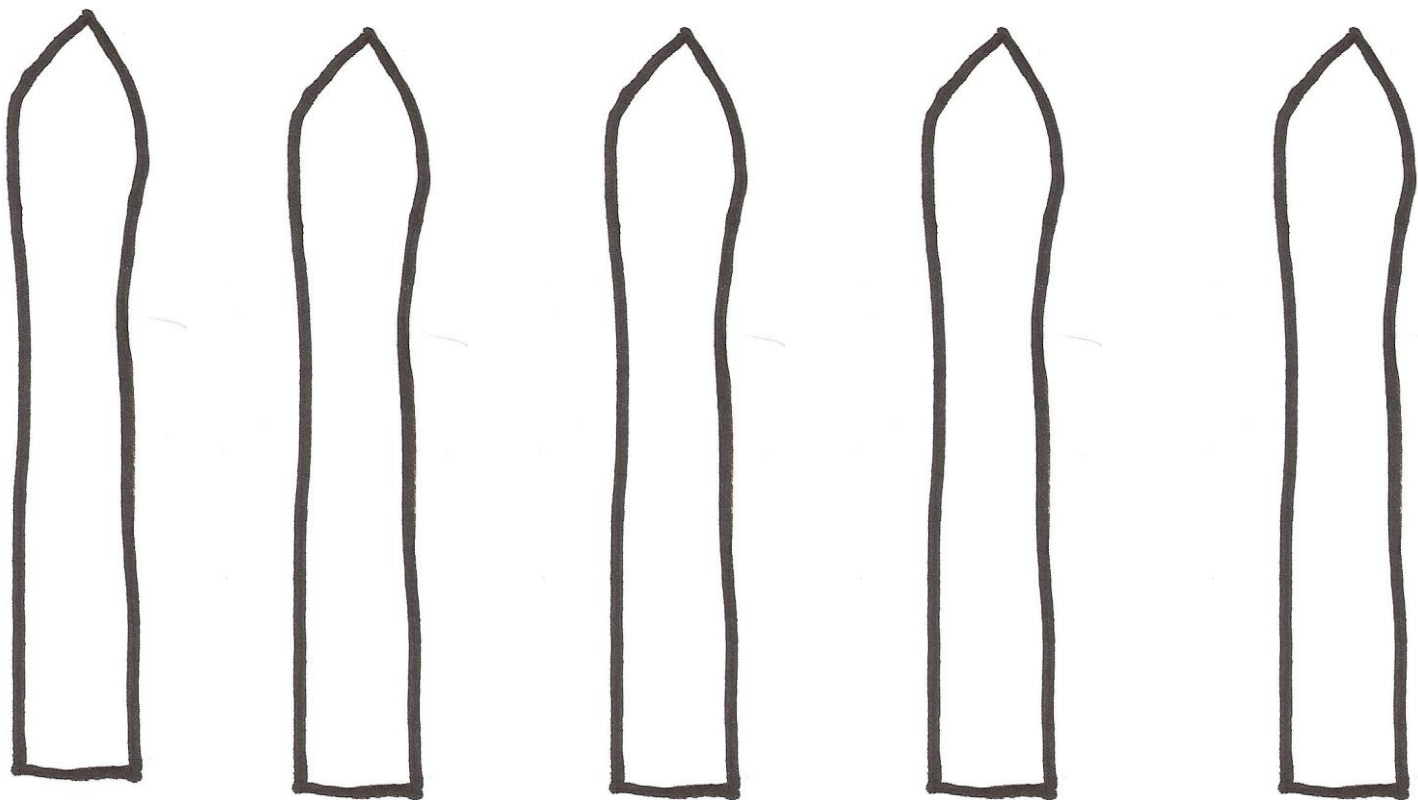
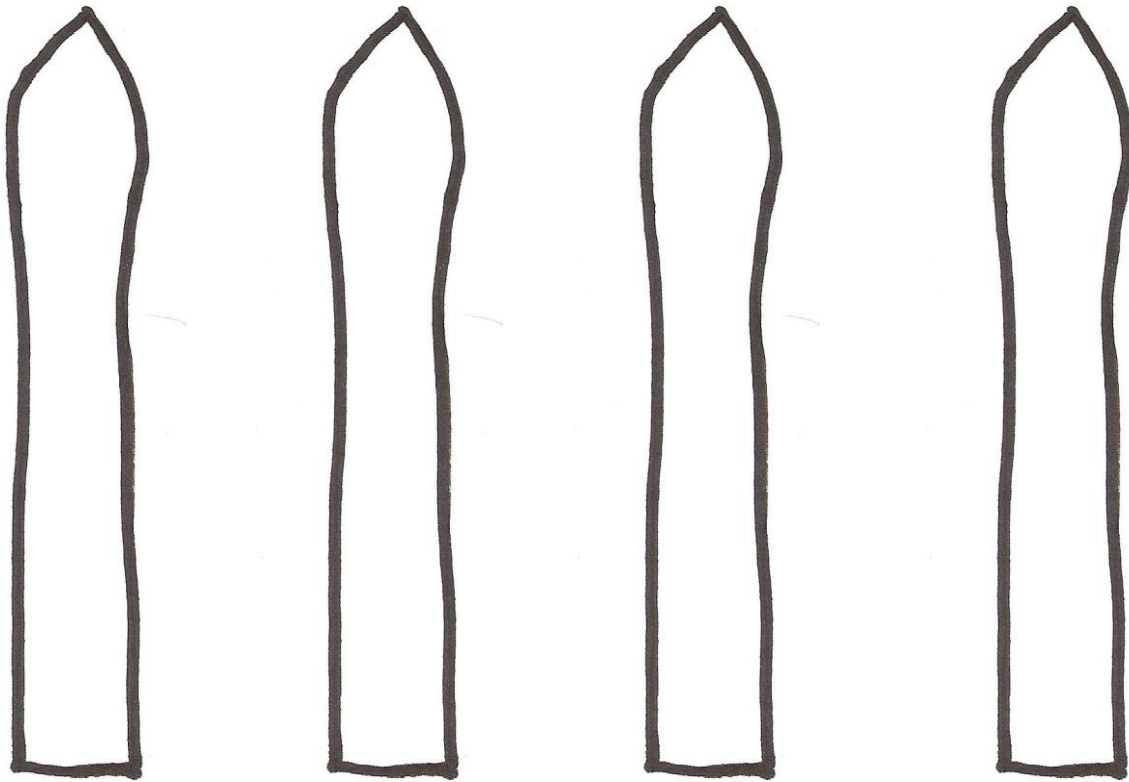

primary junction

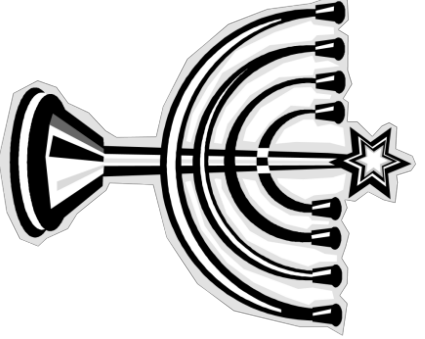
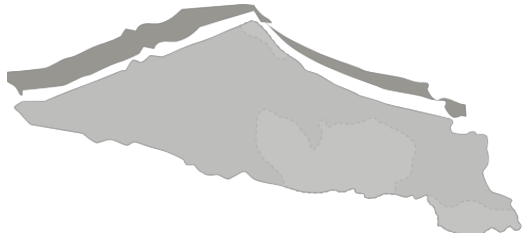
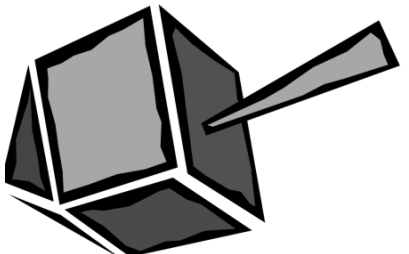

# Hanukkah in Israel

Children make crafts, sing songs, and act in plays at school. Hanukkah is not a time for giving gifts, but sometimes small gifts like candy and a dreidel, a spin toy, are given.

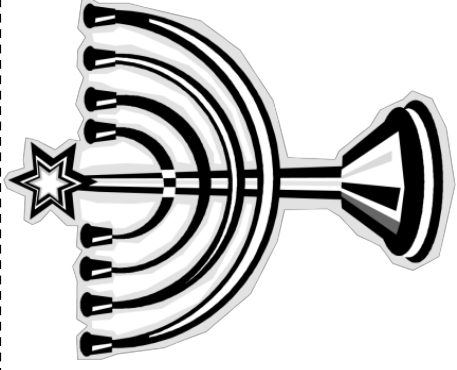
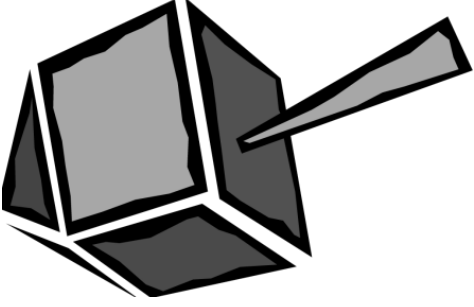

Around early December those celebrating Hanukkah place eight candles in a Menorah. One candle is lit each night. This honors a time when a lamp with only enough oil for one day lasted for eight days.

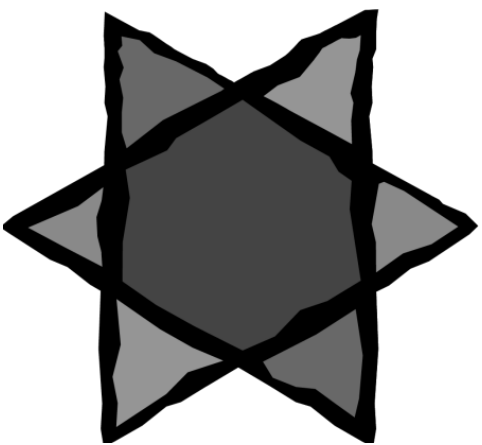

People sometimes celebrate holidays other than Christmas. In Israel, most people celebrate Hanukkah. Hanukkah is the Jewish Festival of Lights.

# ISRAEL

NAME \_\_\_\_\_

Where in the world  
is Israel?

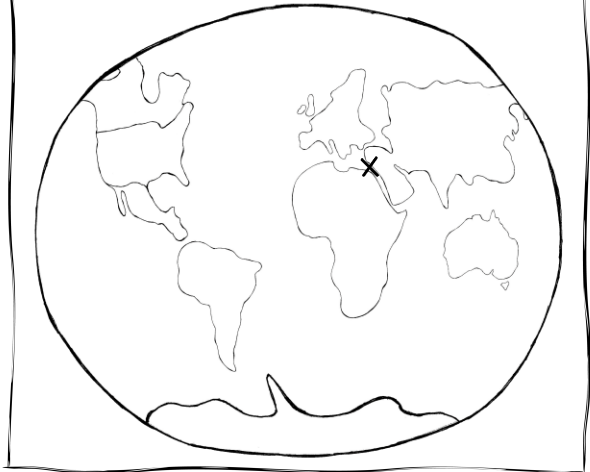

People sometimes celebrate holidays other than Christmas. In Israel, most people celebrate Hanukkah (also spelt Chanukah). Hanukkah is the Jewish Festival of Lights. It begins in November or December, depending on the year, and lasts for eight days. Millions of people throughout the world, not just in Israel, who are of the Jewish faith, celebrate Hanukkah.

Thousands of years ago after Jews saved the Temple of Jerusalem, they wanted to light a lamp. They only found enough oil to last for one night, but the oil lasted for eight nights! They call this the Miracle of the Oil. Every year after this, Jews remember the day with the Festival of Lights. They place eight candles in a Menorah. The Menorah also has a spot for one more candle that is used to light the eight candles. The eight candles stand for the eight nights of Hanukkah. One candle is lit each night.

In Israel, Hanukkah is a special time. Children make crafts, sing songs, go to parties, and act in plays at school. Hanukkah is not a time for giving gifts, but if gifts are given, they are small. Candy and dreidels are sometimes given.

Hanukkah is special to the people of Israel and the Jewish faith.

# ISRAEL READING CHECK

1. Which holiday is celebrated in Israel?

- A) Christmas                      B) Hanukkah                      C) Christmas Eve

2. How long does Hanukkah last?

- A) One day                      B) Eight days                      C) Nine days

3. What is the author's purpose for writing this article?

---

---

---

4. A Menorah holds \_\_\_\_\_ candles.

- A) 1                      B) 8                      C) 9

5. Hanukkah is also called \_\_\_\_\_?

- A) Menorah                      B) Festival of Lights                      C) Miracle of Oil

6. Which of the gifts below might a child celebrating Hanukkah receive?

- A) Dreidel                      B) Video Game                      C) Remote Controlled Car

7. What is the Miracle of Oil?

---

---

---

---

---

8. What is the main idea in this article?

---

---

---

9. Create a new title for this article.

---

---

---

10. What might a child in Israel do during Hanukkah?

---

---

---

---

---



# ISRAEL

NAME \_\_\_\_\_

Where in the world  
is Israel?

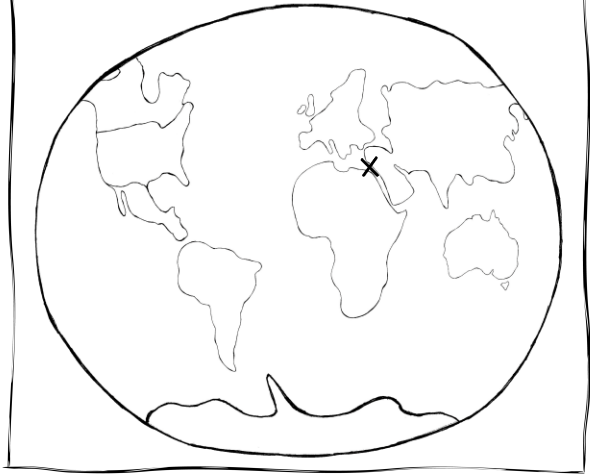

Christmas is not celebrated by everyone. People sometimes celebrate other holidays. In Israel, most people celebrate Hanukkah (also spelt Chanukah). Hanukkah is the Jewish Festival of Lights. It begins in either late November or December, depending on the year, and lasts for eight days. Hanukkah isn't celebrated in only Israel. Millions of people throughout the world who are of the Jewish faith observe Hanukkah.

Thousands of years ago Jewish rebels defeated their Syrian ruler after three long years. After restoring the Temple of Jerusalem, the group wanted to light the eternal lamp. They found only enough oil to last for one night, but somehow the oil lasted for eight nights. This is known as the Miracle of the Oil.

After The Miracle of the Oil, it was decided that every year Jews would remember the day with the Festival of Lights. During this time, they place eight candles in a Menorah, which is an eight-branched candelabra with a ninth branch for a "helper" candle, called the Shamash. Each of the eight candles represent one of the eight nights of Hanukkah. One candle is lit each night. The Menorah is usually placed near a window or front door for others to see.

In Israel, Hanukkah is a very joyous occasion. Weeks before Hanukkah arrives, children make crafts, sing songs, and participate in parties and plays at school. During Hanukkah, school is closed, so many families travel. It is not a time for giving gifts. If any presents are given, they are usually small such as candy or a dreidel. Latkes, which are potato pancakes, and jelly doughnuts are treats that are enjoyed during Hanukkah.

Hanukkah is very important to the people of Israel and the Jewish faith.

# ISRAEL READING CHECK

1. Which holiday is celebrated in Israel?

- A) Christmas                      B) Hanukkah                      C) Christmas Eve

2. How long does Hanukkah last?

- A) One day                      B) Eight days                      C) Nine days

3. What is the author's purpose for writing this article?

\_\_\_\_\_

.....

\_\_\_\_\_

4. A Menorah holds \_\_\_\_\_ candles.

- A) 1                      B) 8                      C) 9

5. Hanukkah is also called \_\_\_\_\_?

- A) Menorah                      B) Festival of Lights                      C) Miracle of Oil

6. Which of the following gifts might a child celebrating Hanukkah receive?

- A) Dreidel                      B) Video Game                      C) Remote Controlled Car

7. What details would you include in a summary of this text?

\_\_\_\_\_

.....

\_\_\_\_\_

.....

\_\_\_\_\_

8. What is the main idea in this article?

\_\_\_\_\_

.....

\_\_\_\_\_

9. Create a new title for this article. Explain why this would be a good title.

\_\_\_\_\_

.....

\_\_\_\_\_

10. Identify a text feature used in this article and explain what you learned from using it.

\_\_\_\_\_

.....

\_\_\_\_\_

.....

\_\_\_\_\_

Welcome To

Israel

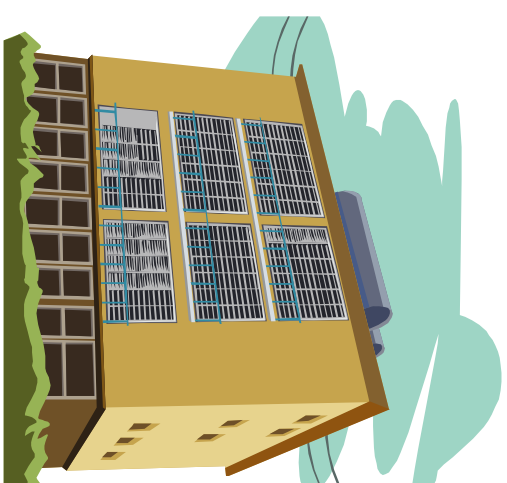
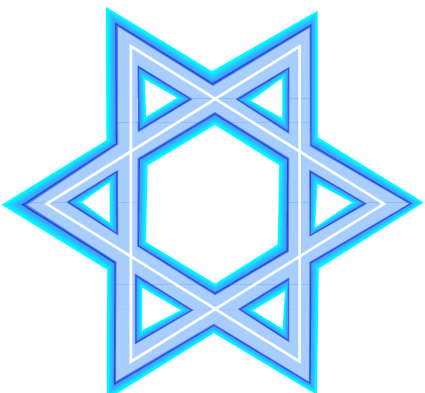

Shalom

means "Hello"  
Pronounced Sha-lome

# mexico



**Poinsettia**

**Purpose:** It is believed that a young boy walking to the church to see the nativity scene showing the birth of Jesus realized on the way that he had no gift to offer so he gathered up some plain green branches as he walked in. He was laughed at but once he placed the branches near the manger they started to bloom a bright red poinsettia flower on each branch.

## **Materials:**

- Red and green construction paper
- Leaf Template
- Yellow Tissue Paper
- Glue Stick
- Scissors

## **Procedures:**

1. Print leaf template onto both red and green construction paper. Each student will receive a copy of each.
2. Students will cut out leaves and circle.
3. Students will glue the red petals onto the green circle so they overlap slightly.
4. Flip the circle over and glue the green leaves in between the red petals.
5. Flip the circle over and glue crumpled pieces of yellow tissue paper or hole-punched pieces of yellow construction paper in the middle.

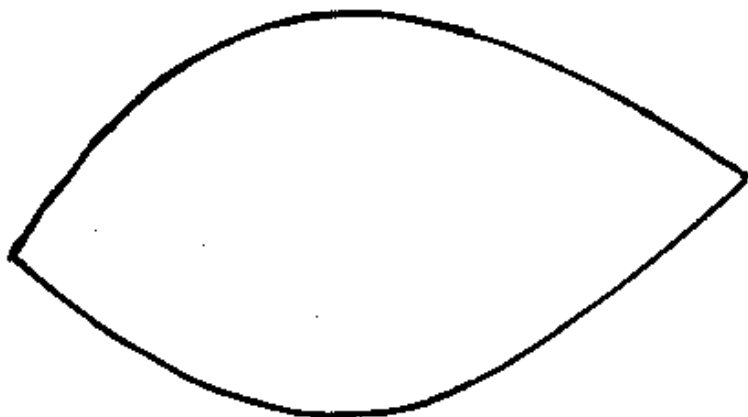
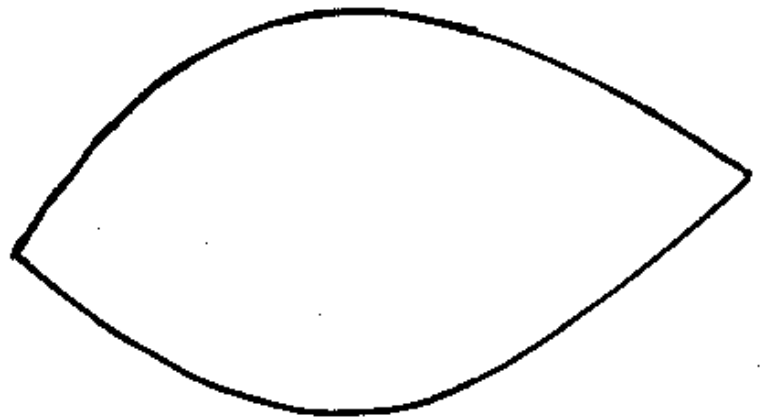
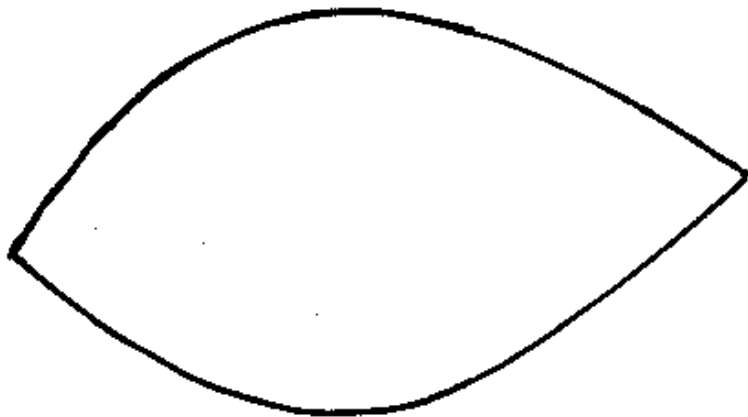
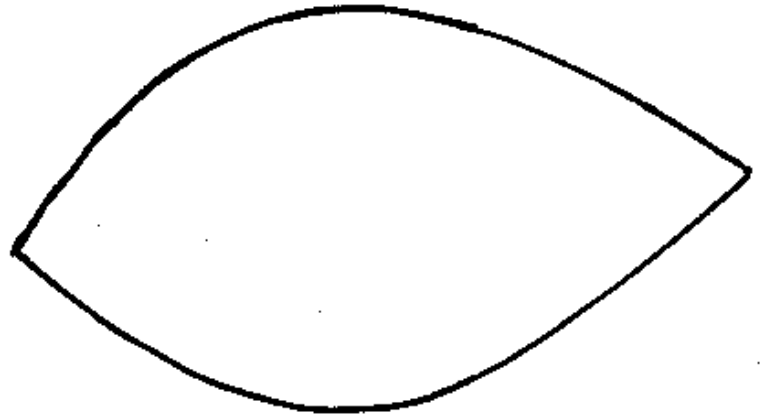
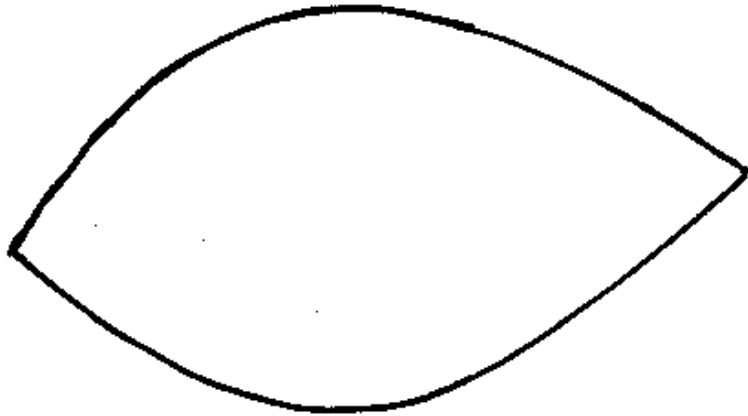
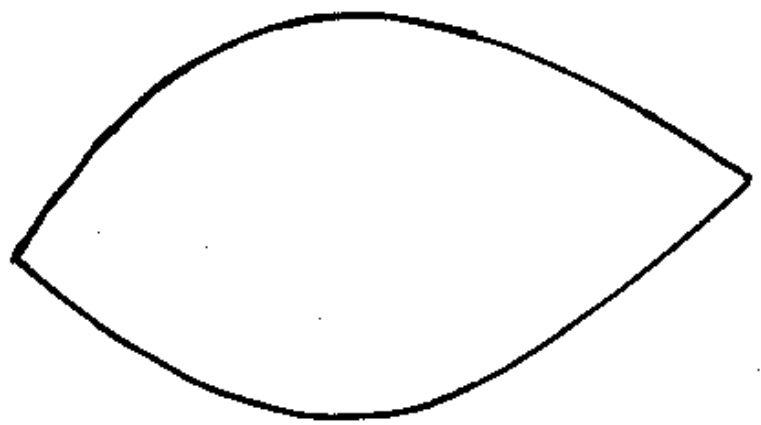
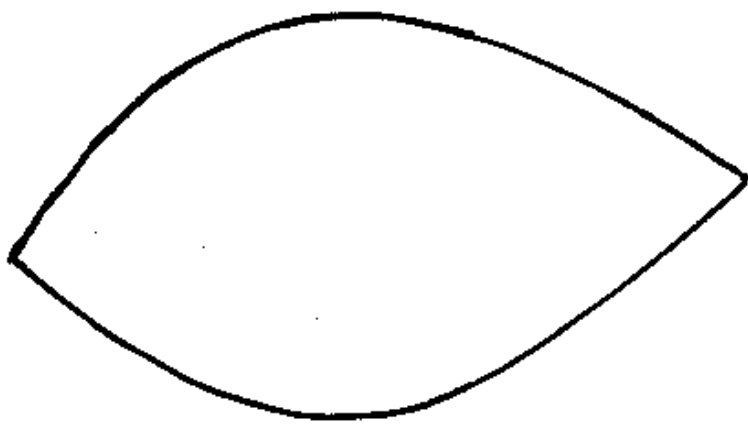

**RED  
POINSETTIA  
LEAVES**

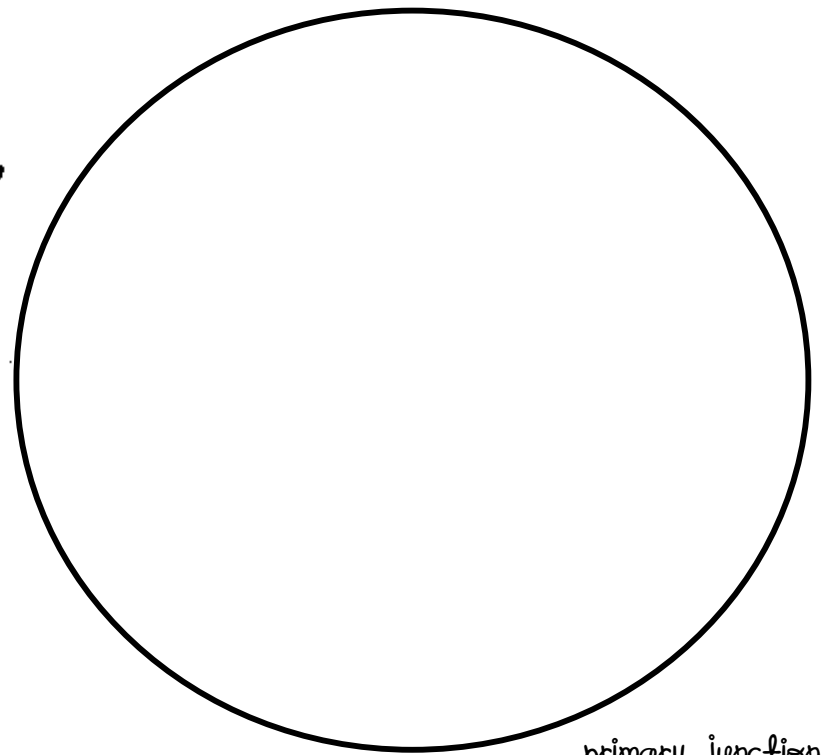
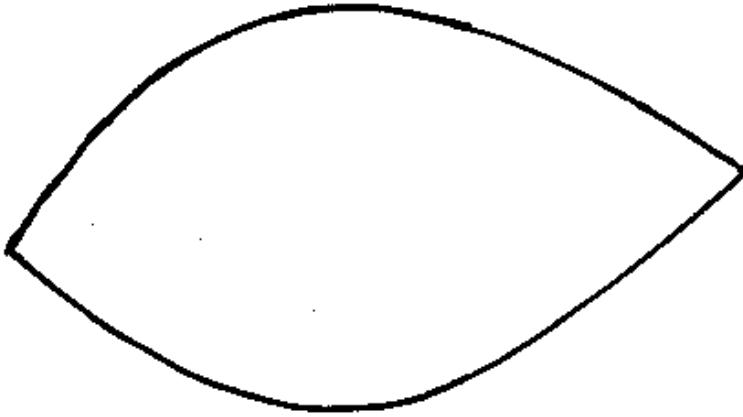
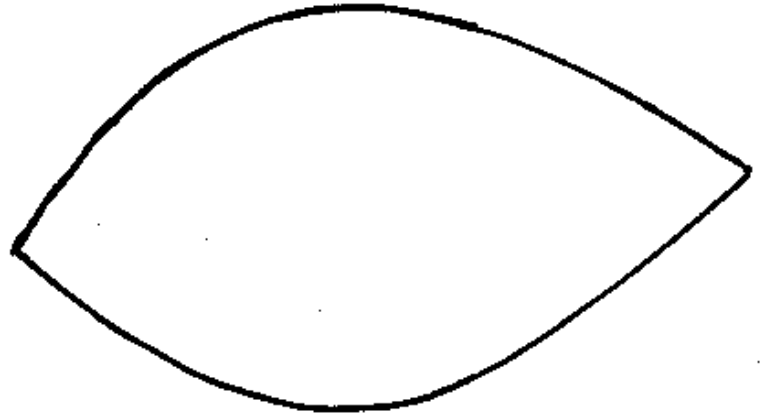
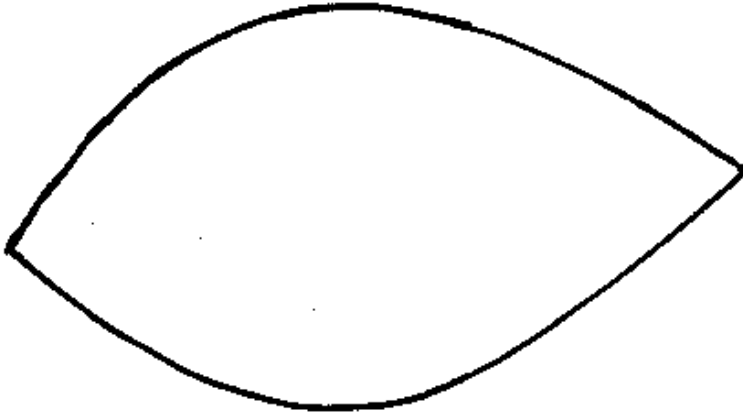
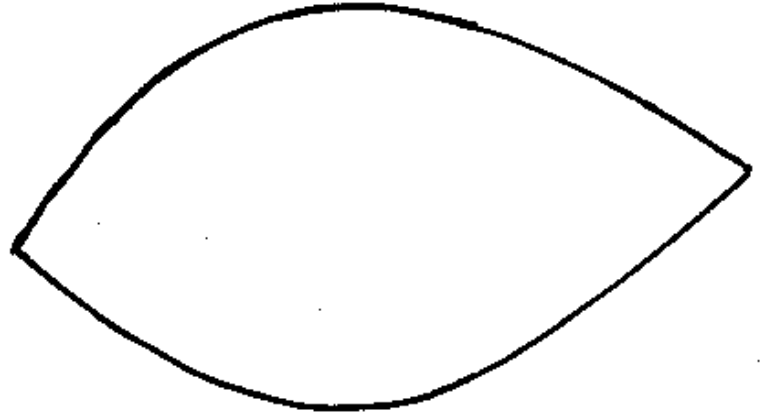
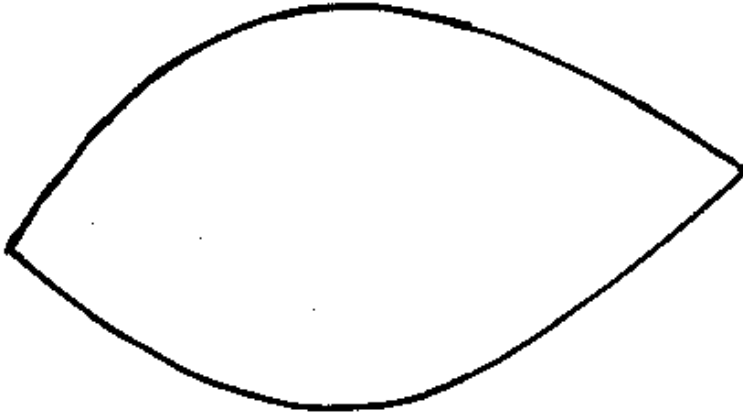
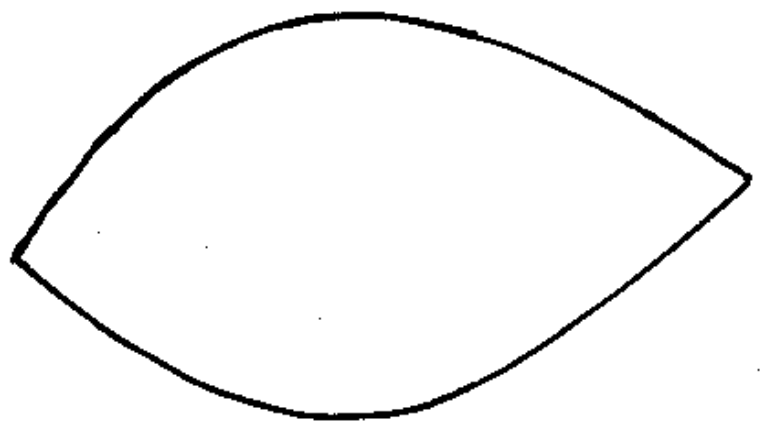
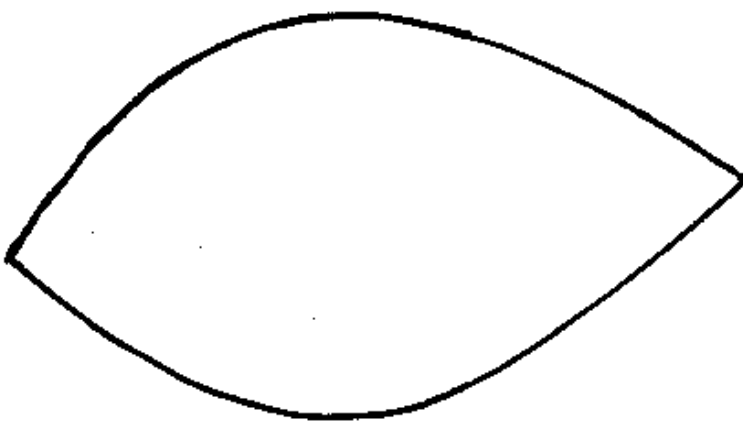

**Green Poinsettia  
Leaves  
AND Circle**



# Christmas in Mexico

Another sign of Christmas in Mexico is the poinsettia. It is a bright red, star-shaped flower. It is said a boy walking to the nativity scene took green branches. When he got there, he put the branches near the manger, and they bloomed right away into a poinsettia!

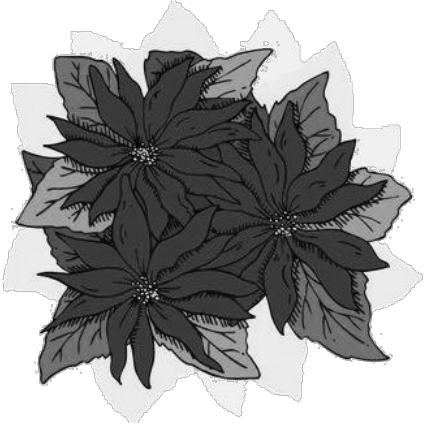

La Posada, which celebrates the Christmas story of Mary and Joseph looking for an inn, is a family event. Children visit homes for nine nights looking for a room.

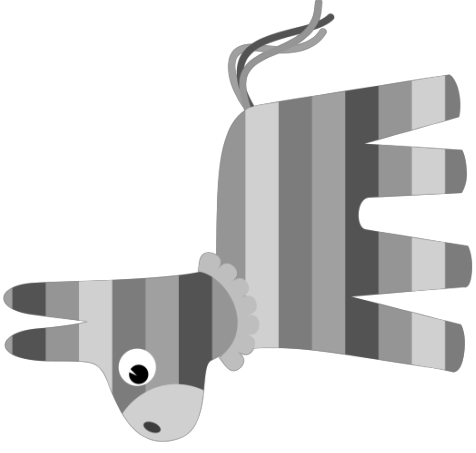

On the ninth night, they finally find a home with room. After this, they might have a party. The children play with a piñata, an object filled with candy that is high off the ground. They take turns hitting it until the candy falls out.

# MEXICO

NAME \_\_\_\_\_

where in the world  
is Mexico?

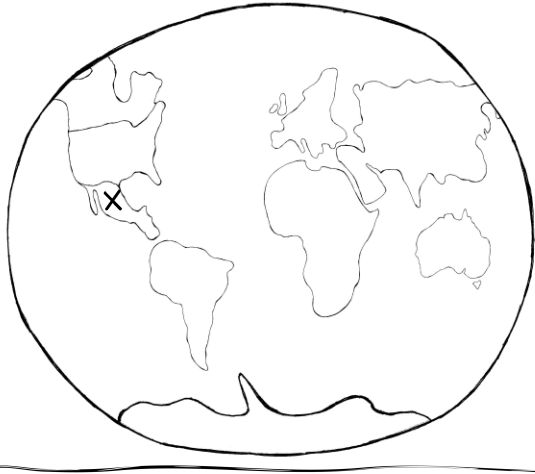

In Mexico, Christmas is celebrated from December 16 to January 6. La Posada, which is Spanish for 'the inn', is the main Christmas celebration. It begins on December 16 and lasts for nine days. La Posada celebrates the story of Mary and Joseph looking for an inn. Once a night, children visit neighbors and sing a song at each home. For the first eight nights they are told there is no room in the house. Finally, on the ninth night, they are told there is room and they may come in. Inside, there is a party. There, the children might play with a piñata, a paper-mâché object filled with candy that is high off the ground. To play, children are blind-folded and take turns hitting the piñata with a stick until the candy pours out.

In Mexico, children get gifts on January 6, which is El Dia de los Reyes (The Day of The Three Kings). The gifts are left by The Three Kings. On this day, many families eat a Three Kings Cake. Inside, a figure of Baby Jesus is hidden. Whoever finds the figure in their piece of cake becomes the 'Godparent of Jesus' for the year.

A known sign of Christmas in Mexico is the poinsettia. It is a bright red, star-shaped flower. It is said that a young boy walking to the nativity scene to see Baby Jesus soon realized he had no gift to give him. He soon thought to take green branches he saw nearby. When he got to the nativity scene, he put the branches near the manger. They bloomed right away into a poinsettia!

Christmas in Mexico is indeed a special time.





# MEXICO

NAME \_\_\_\_\_

where in the world  
is Mexico?

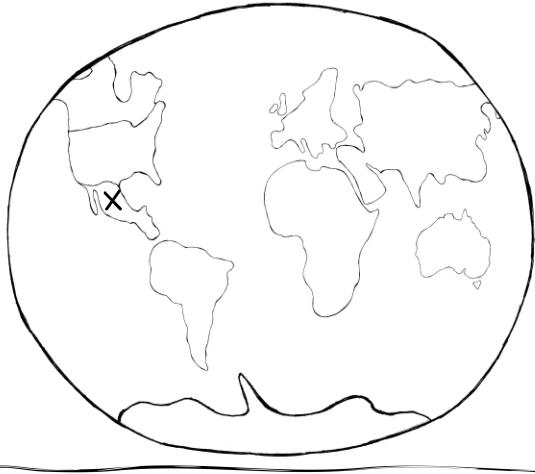

In Mexico, Christmas is celebrated from December 16<sup>th</sup> to January 6<sup>th</sup>. La Posada, which is Spanish for 'the inn', is the main Christmas celebration. It begins on December 16<sup>th</sup> and lasts for nine days before coming to an end on December 24. La Posada celebrates the part of the Christmas story where Mary and Joseph looked for an inn. Once a night, children are given candles and a painted board with Mary and Joseph. They call neighbors and sing a song at each home. For the first eight nights they are told there is no room in the house. Then, finally, on the ninth and final night, they are told there is room at the house and they may come in. Inside, the children celebrate with a party. At the party, they might play with a piñata. A piñata is a decorated paper-mâché object filled with candy and hung from an area high off the ground. To play, children are blind-folded and take turns hitting the piñata with a stick until the candy pours out.

When the families go to Christmas Eve church service, a baby Jesus is placed into the manger. Afterward, there are fireworks. In Mexico, children receive their presents on January 6, which is El Dia de los Reyes (The Day of The Three Kings). The presents are left by The Three Kings. On this day, many families eat a Three Kings Cake. Inside, a figure of Baby Jesus is hidden. Whoever finds the figure in their piece of cake becomes the 'Godparent of Jesus' for the year.

A very well-known symbol of Christmas in Mexico is the poinsettia, which is a bright red, star-shaped flower. It is said that a young boy who was walking to the nativity scene to see Baby Jesus soon realized he had no gift to offer him. Looking around, he decided to take some green branches he saw nearby. When he arrived at the nativity scene he placed the branches near the manger. Surprisingly, they began to bloom into a poinsettia!



*see*

*see*

*see*

Welcome To

Mexico

*see*

*see*

*see*

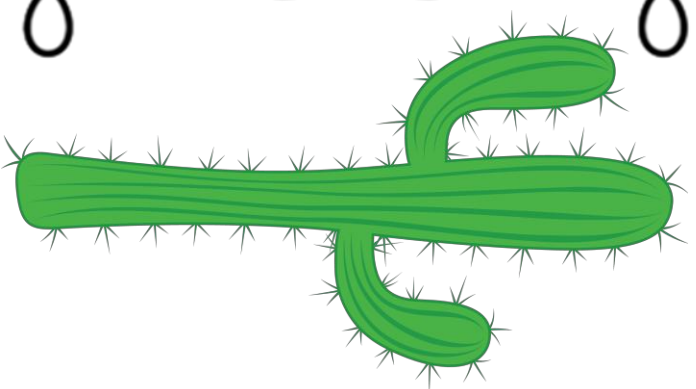

Hola



means "Hello"  
Pronounced oh-*la*

# sweden



## Saint Lucia's Day (Also known as Saint Lucy's Day) Candle Crown

**Purpose:** St Lucia was a young Christian girl who was killed for her faith in 304AD. She secretly brought food to the persecuted Christians in Rome. She would wear candles on her head so she would have both hands free to carry things. St. Lucia's Day is now celebrated by a girl dressing in a white dress with a red sash round her waist and a crown of candles on her head. (Normally electric candles are used for safety!) The crown is made of Lingonberry branches which are evergreen and symbolize new life in winter.

### Materials:

- White Sentence Strip
- One Page of Green Leaves (Copy onto green construction paper or cardstock)
- Four Candles (Copy onto white construction paper or cardstock)
- Yellow Crayon
- Stapler

### Procedures:

1. Give each student a copy of the required materials.
2. Students will color the candle flames and then cut them and the leaves out.
3. Once all materials are cut out students should glue their leaves side-by-side onto their sentence strip.
4. Students will then glue their four candles on the inside of their sentence strip after evenly spacing them out along the strip.
5. Finally, the teacher or assistant will come around to measure the sentence strip to fit on the student's head and staple it to make a crown.

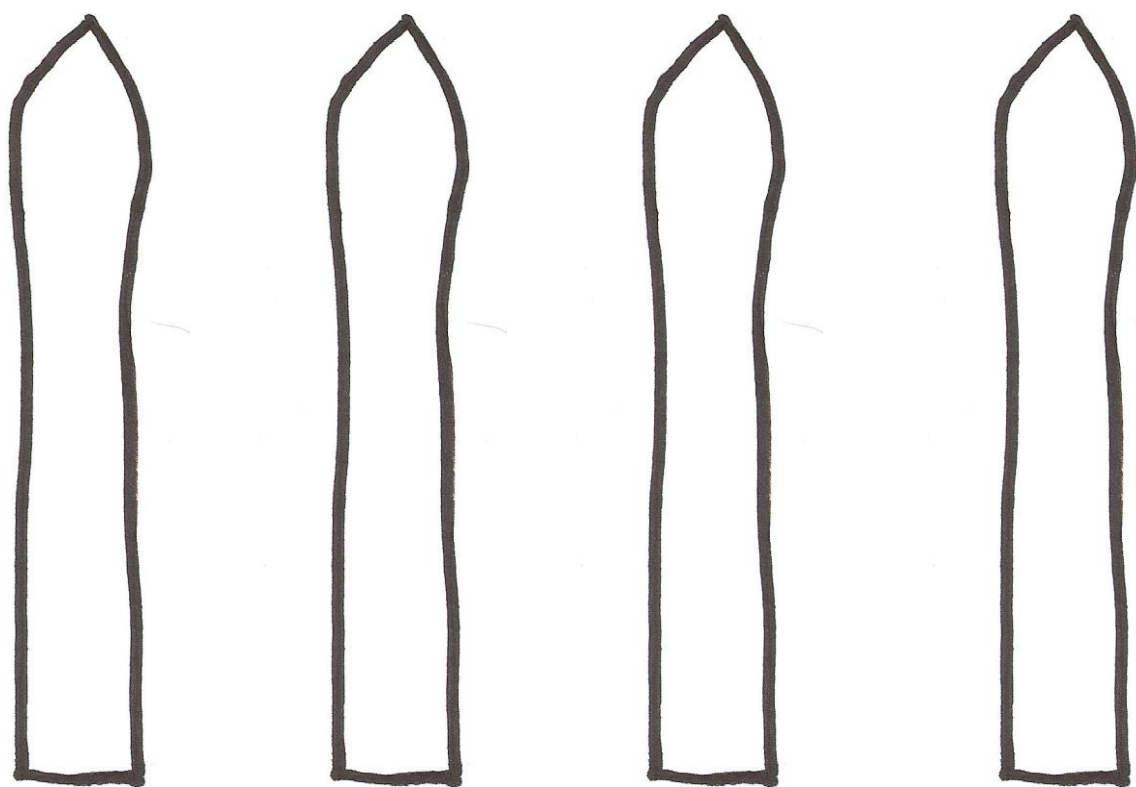
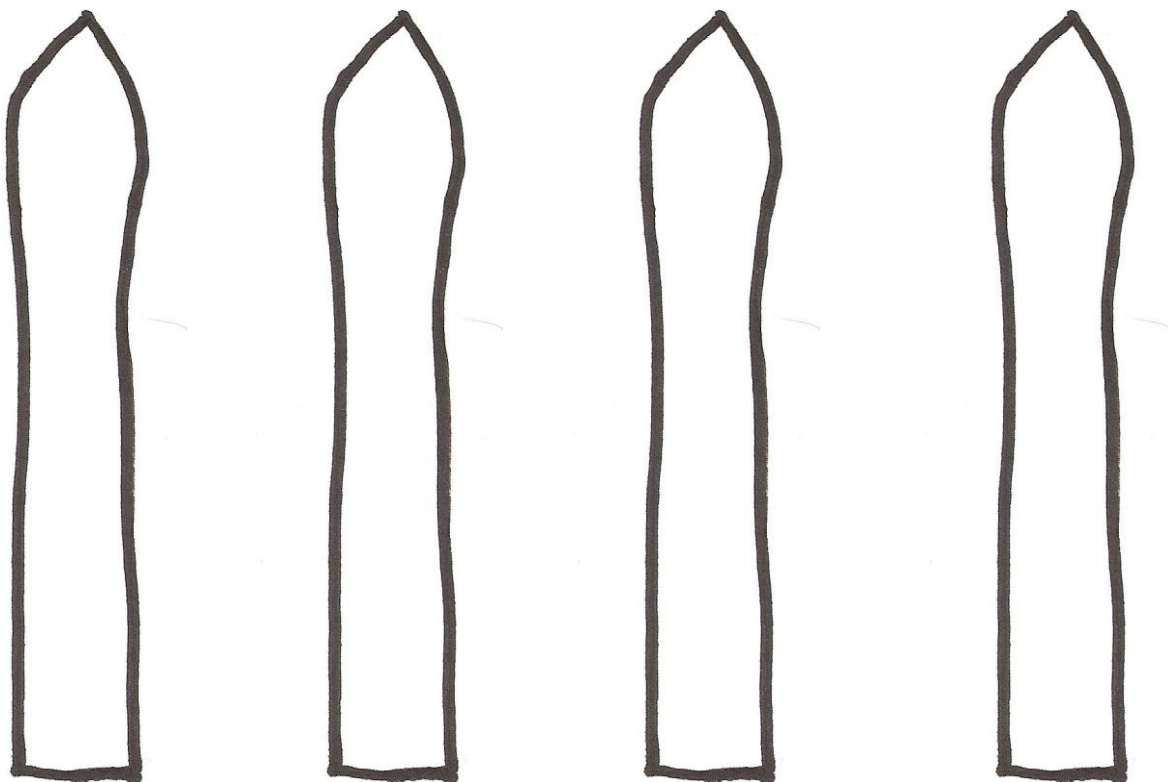

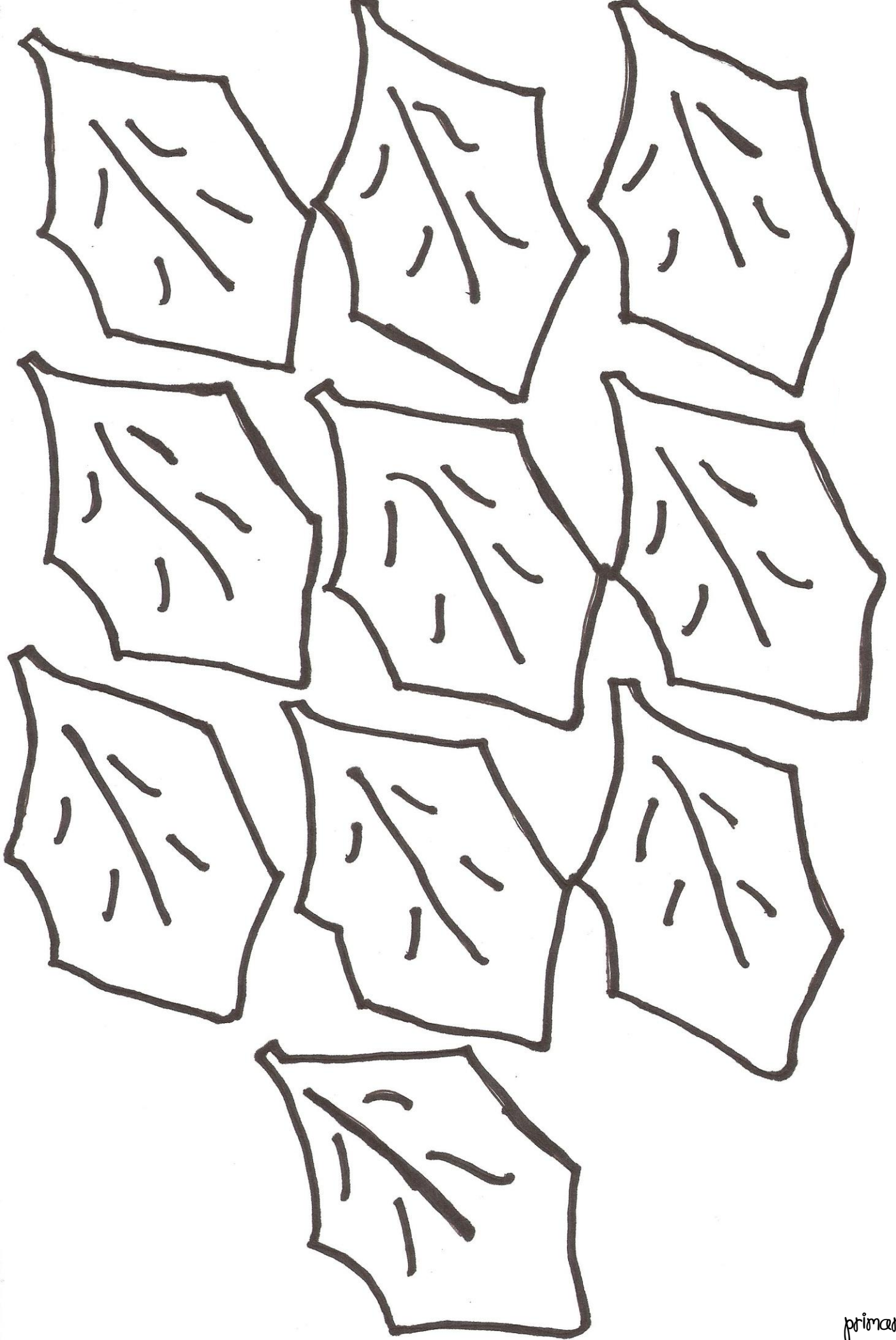



# Christmas in Sweden

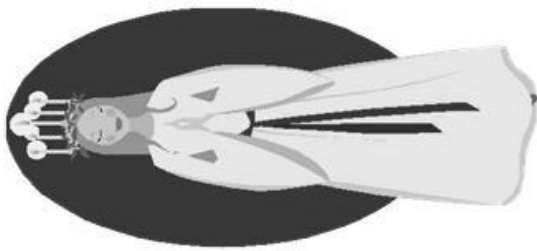

Christmas in Sweden begins on Saint Lucia's Day. A girl in each family will put on a white robe with a red sash. She also wears a crown covered in evergreens and lighted candles.

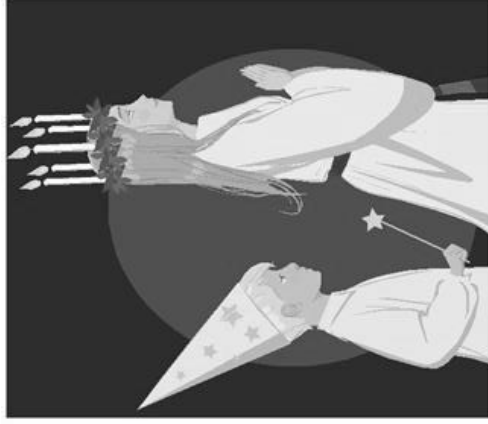

Then, the girl and her family go to church. Many children walk to church in a line. Often only one girl will wear the crown, while others carry just one candle. Boys wear pointed hats and carry star wands.



On Christmas Eve, homes are visited by Jultomten (Santa/Father Christmas) or by a gnome named Tomte. On Christmas morning, families go to church.



# SWEDEN

NAME \_\_\_\_\_

where in the world  
is Sweden?

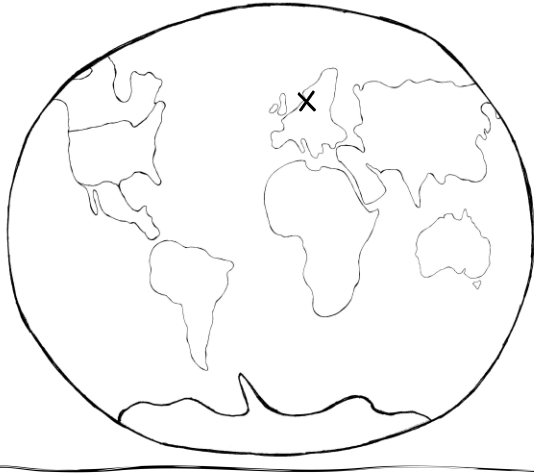

Christmas in Sweden starts on December 13. That is Saint Lucia's Day. It is not a holiday, but it is a big day. On this day, a girl in each family will put on a white robe with a red sash. She also wears a crown with evergreens and lighted candles. After she is ready, she wakes her parents and gives them coffee and Lucia buns, which are flavored with saffron and cinnamon and have currants inside. Then, the girl and her family go to church. Today, many children walk to church in a line. Often only one girl will wear the crown, while the others, who are also dressed in white, carry one candle. The girls are followed by boys wearing pointed hats and carrying star wands. Many cities and schools pick their own Saint Lucia every year. They visit malls, nursing homes, and schools.

At home, Christmas trees are not put up until two days before Christmas. Tree decorations may include Swedish flags, small gnomes, straw ornaments, and candles. Some families might have straw goats in front of their trees.

On Christmas Eve, families gather for a Swedish Julafton, which is a buffet. Dishes may include ham, pickled pigs feet, dried codfish, and pepparkakor, which is a heart-star or goat-shaped gingerbread biscuit. There might also be Risgryngrot at the table. It is rice porridge that has an almond hidden in it. Tradition says the person who finds the almond will marry in the coming year. On this night, homes are visited by Jultomten (Santa/Father Christmas) or by a gnome named Tomte. Finally, on Christmas morning, families go to church. Churches are often lit by candle.

Christmas in Sweden is magical.

# SWEDEN READING CHECK

1. On what day do girls wear a white robe, red sash, and an evergreen crown?  
A) Christmas Eve                      B) Christmas                      C) Saint Lucia's Day

2. What food item below is flavored with saffron and cinnamon or nutmeg?  
A) Lucia Buns                      B) Julafton                      C) Risgröngrot

3. What decorations might you find on a Swedish Christmas tree?

\_\_\_\_\_

\_\_\_\_\_

\_\_\_\_\_

4. How does the author describe the hats boys wear on Saint Lucia's Day?  
A) Round                      B) Pointed                      C) Soft

5. What is the name of the gnome who may visit children on Christmas Eve?  
A) Jultomten                      B) Tomte                      C) Saint Lucia

6. When is Saint Lucia's Day?  
A) December 13                      B) December 24                      C) December 25

7. The author says that Christmas in Sweden is "magical". Is this an opinion or fact? Explain.

\_\_\_\_\_

\_\_\_\_\_

\_\_\_\_\_

8. What is a pepparkakor?

\_\_\_\_\_

\_\_\_\_\_

9. Write one fact about Saint Lucia's Day.

\_\_\_\_\_

\_\_\_\_\_

\_\_\_\_\_

10. How is Christmas in Sweden both similar and different from your traditions?

\_\_\_\_\_

\_\_\_\_\_

\_\_\_\_\_

# SWEDEN

NAME \_\_\_\_\_

where in the world  
is Sweden?

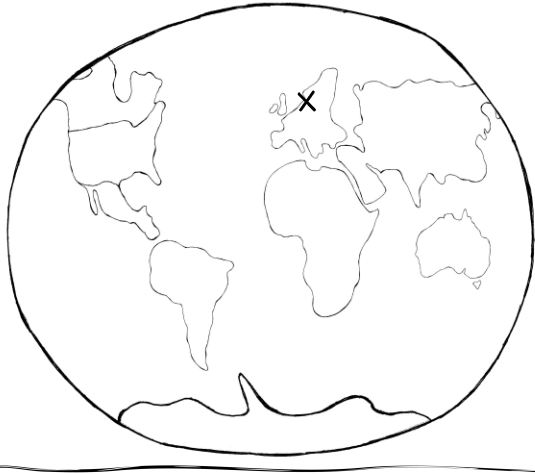

Christmas in Sweden begins on the morning of December 13. That is Saint Lucia's Day. It is not an official holiday, but it is a very popular event. Saint Lucia's Day honors a young girl who was killed around the year 310 for her beliefs. On the morning of St. Lucia's Day, a girl in each family will put on a white robe with a red sash. She also wears a crown covered in evergreens with lighted candles attached to it. After she is ready, she wakes her parents and serves them coffee and Lucia buns, which are flavored with saffron and cinnamon or nutmeg, and contain currants. Then, the girl and her family head to church. Today, it is popular for many children to walk to church in a line. Often only one girl will wear the crown, while the others, who are also dressed in white, carry one candle. The girls are followed by boys wearing pointed hats and carrying star wands. It is popular for cities and schools to choose their own Saint Lucia every year. The Saint Lucias visit malls, nursing homes, and schools.

At home, Christmas trees are not put up until two days before Christmas. Tree decorations may include Swedish flags, small gnomes, straw ornaments, and candles. Some families might have straw goats in front of their trees. On Christmas Eve, families gather for a Swedish Julafton, which is a buffet. Dishes may include ham, pickled pigs feet, dried codfish, pepparkakor, which is a heart-star or goat-shaped gingerbread biscuit. There might also be Risgryngrot at the table. It is rice porridge that has an almond hidden in it. Tradition says that the person who finds the almond will marry in the coming year.

On Christmas Eve, homes are visited by Jultomten (Santa/Father Christmas) or by a gnome named Tomte. On Christmas morning, families go to church. Churches are often lit by candle.

Christmas in Sweden is certainly magical.

# SWEDEN READING CHECK

1. On what day do girls wear a white robe, red sash, and an evergreen crown?  
A) Christmas Eve                                      B) Christmas                                      C) Saint Lucia's Day

2. What food item below is flavored with saffron and cinnamon or nutmeg?  
A) Lucia Buns                                      B) Julafton                                      C) Risgringrot

3. What decorations might you find on a Swedish Christmas tree?  
\_\_\_\_\_  
\_\_\_\_\_  
\_\_\_\_\_

4. How does the author describe the hats boys wear on Saint Lucia's Day?  
A) Round                                      B) Pointed                                      C) Soft

5. What is the name of the gnome who may visit children on Christmas Eve?  
A) Jultomten                                      B) Tomte                                      C) Saint Lucia

6. When is Saint Lucia's Day?  
A) December 13                                      B) December 24                                      C) December 25

7. What two text features could the author add to help you better understand the article?  
\_\_\_\_\_  
\_\_\_\_\_  
\_\_\_\_\_

8. How did you use your prior knowledge to understand this article?  
\_\_\_\_\_  
\_\_\_\_\_

9. What details from this article would you include in a summary of the text?  
\_\_\_\_\_  
\_\_\_\_\_  
\_\_\_\_\_

10. How is Christmas in Sweden both similar and different from your traditions?  
\_\_\_\_\_  
\_\_\_\_\_  
\_\_\_\_\_

Welcome to

Sweden

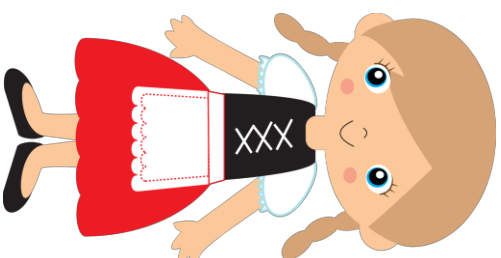

Halla

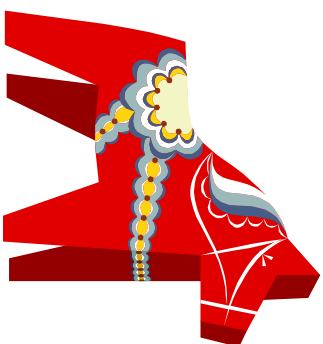

means "Hello"  
pronounced hallo

# Thank you!

Thank you so much for your purchase! I hope you and your students will enjoy learning how Christmas and other holidays are celebrated!

If you have any questions or concerns, please contact me at

[primaryjunctionblog@gmail.com](mailto:primaryjunctionblog@gmail.com).

for more lesson ideas and freebies, please visit:

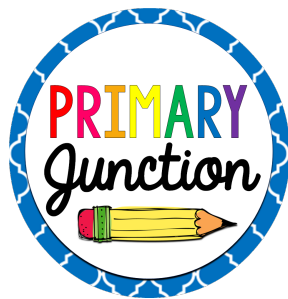

graphic and font credits:

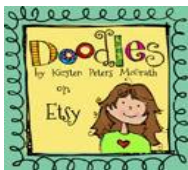

BUY TWO  
3rd will be  
**FREE**

